

Rainwater Harvesting Aboveground Tank Model RWH (36) 300

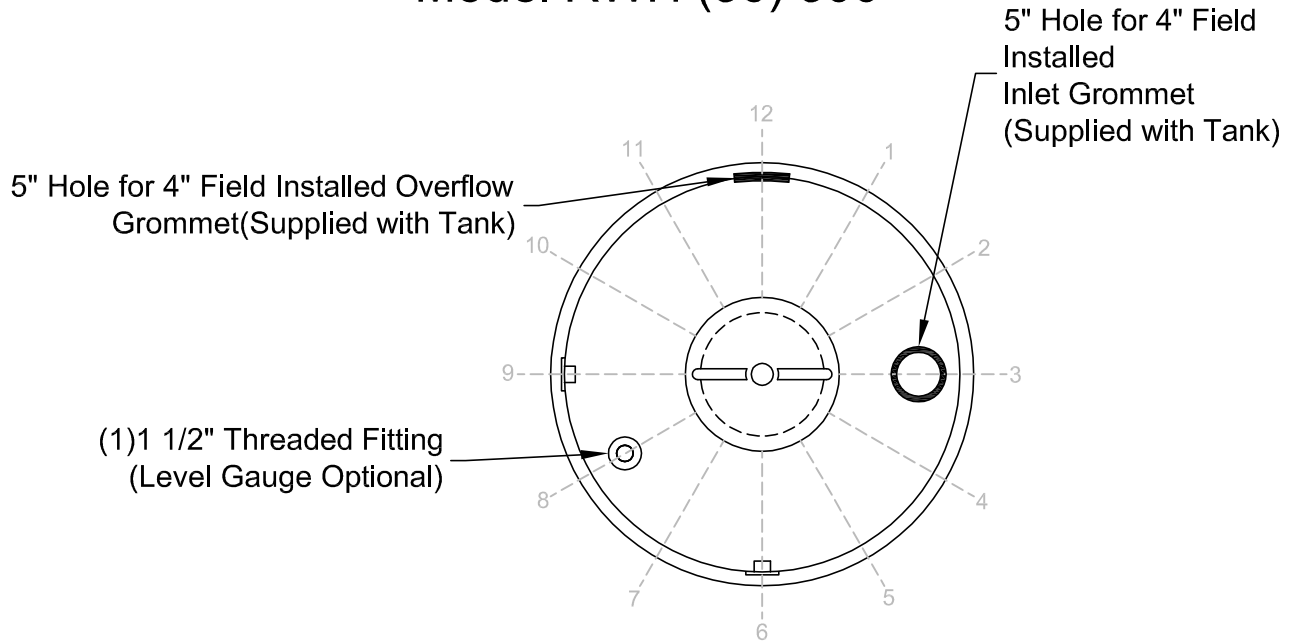

TOP VIEW

14" O.D. Access Lid
(11 1/4" I.D. Opening)

- | |
|--|
| SEE SPEC #PE-C45.03 |
| Available Finishes (Choose One) |
| <input type="checkbox"/> Natural Fiberglass (Standard) |
| <input type="checkbox"/> Desert Sand |
| <input type="checkbox"/> Forest Green |
| <input type="checkbox"/> 42" dia x 6" Long Foundation Ring (Same Finish as Tank) |

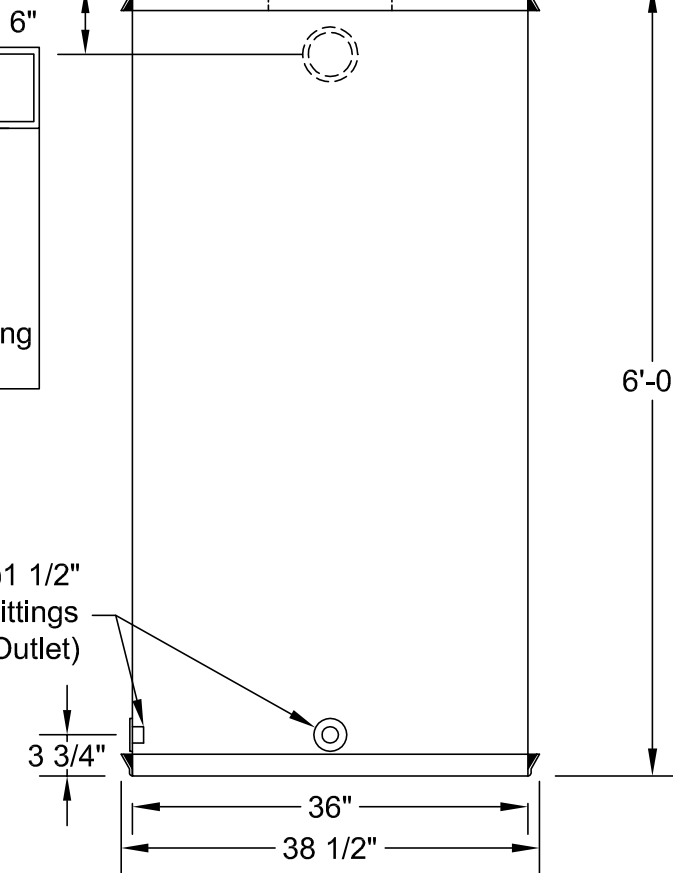

ELEVATION VIEW



CUSTOMER		RWH AGT (36) 300 Gallons				DATE: 7/1/2010
APPROVAL SIGNATURE:	SIGNATURE DATE:	NOM. WEIGHT: 130 LBS.	DRAWN BY: J.HARMON	REV #: B	REV DATE: 1/1/2014	REV BY: RSO
						DWG NUMBER: RWH AGT(36)-300