

FLOWTITE PRODUCTS

GREASE INTERCEPTOR

NOTE: CUSTOMER SUPPLIED
"ASTM C-1644" APPROVED
FLEXIBLE PIPING COUPLING
REQUIRED ON TANGENTIALLY
MTD. NOZZLES, & PIPES

SHELL CODES: 2-EXS05SD



THIS IS AN IAPMO APPROVED TANK
COMPLIANCE STANDARDS AND CODES:
IAPMO/ANSI Z1001
UNIFORM PLUMBING CODE (UPC)
INTERNATIONAL PLUMBING CODE (IPC)
MFG. PER PE-C22.85

CAPACITIES:
LIQUID OPERATING CAPACITY = 8618 GALS
FREE SURFACE AREA OF LIQUID = 193 SQ/FT
GREASE/FOG STORAGE = 4690 GALS/35644 LBS

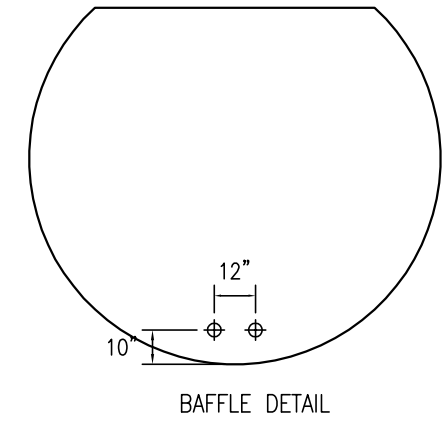
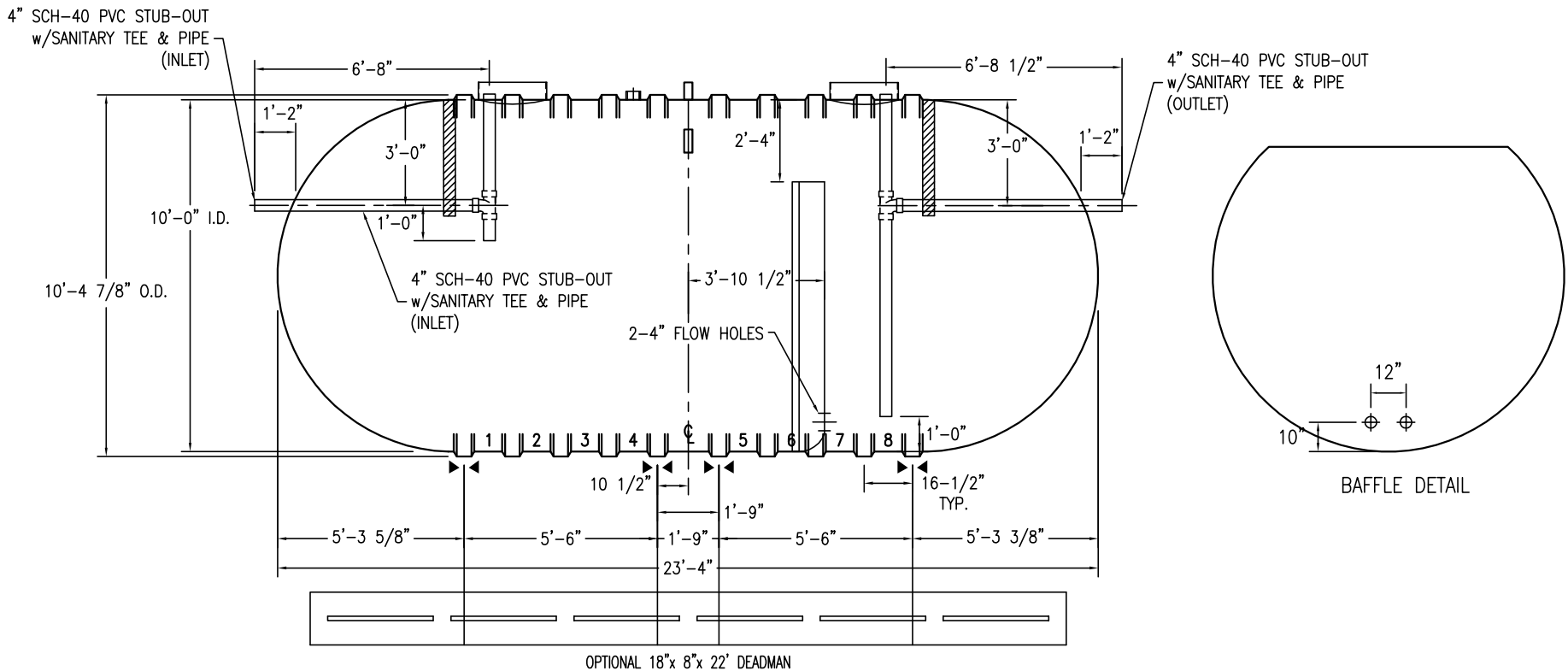
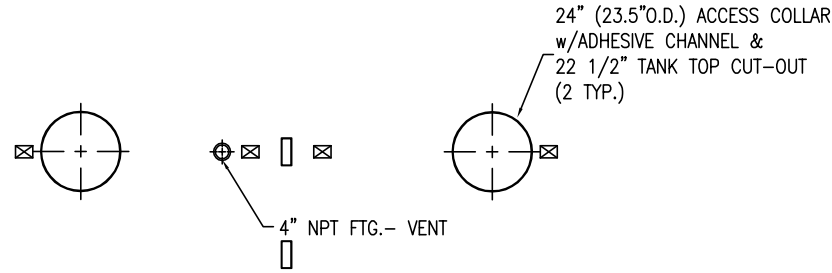

NOTES:

- ☒ HOLD DOWN STRAP CLIP
- ▶◀ HOLD DOWN STRAP LOCATION
- TYPE "13" LIFT LUG - SD
- TYPE "13" LIFT LUG - HD

SWT D6 (10') 8600 2B-IG		DATE: 1/1/2014
IAPMO GREASE INTERCEPTOR		DRAWN BY: R.MOEN
CONTAINMENT SOLUTIONS	CAPACITY: 11,702	REVISED: 02/01/17-A
	WEIGHT: DRY/WET 4250	DWG NUMBER: 1086CSW-IG