

1. INTRODUCTION

- 1.1. The split strap anchor system, also referred to as a man-out-of-hole system, provides a method to attach and tighten the tank anchor straps to concrete deadmen or to an anchor pad without entry into the excavation. The anchoring system is designed for 6', 8', 10' and 12' diameter single, double, and triple-wall underground fiberglass storage tanks.
- 1.2. Follow the Supplemental Instructions as well as all instructions covered in the most recent edition of Containment Solutions, Inc. (CSI) Tank Installation Instructions (Pub. No. INST 6001)
- 1.3. The split strap anchor system components are typically shipped on the same trailer as the tank. Each tank anchor location requires two fiberglass straps and a split strap take-up fixture. A multiple use tightener, one included per shipment, will also be required to tighten the assembly onto the tank.

2. SPECIFICATIONS

2.1. Working Loads:

- 2.1.1. For any anchoring system, the tank strap and all hardware should be designed for appropriate load ratings. All CSI anchoring components meet the required load ratings.
- 2.1.2. The installing contractor is responsible for providing hardware and anchor points of sufficient size and strength. Any components not purchased from CSI must meet all the requirements found in INST 6001.

2.2. Strap Design:

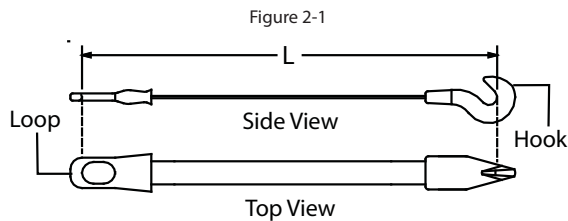

2.3. Strap Dimensions:

Table 2-2

Tank Diameter	Strap Length
6'	64 5/8"
8'	89 1/2"
10'	128 3/8"
12'	152 1/4"

2.4. Take-up Assembly:

Table 2-3

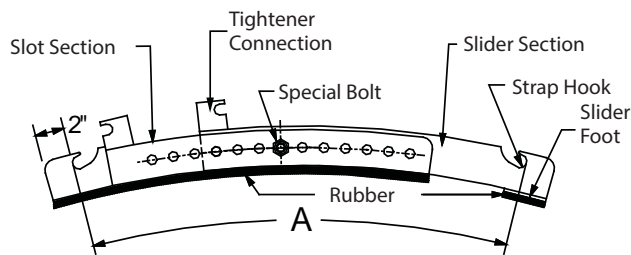

Table 2-4

Minimum A	Maximum A	Weight
26"	43"	16 lbs

- 2.4.1. Take-up assemblies are designed per tank diameter and cannot be used on a different tank diameter.

2.5. Tightener:

Figure 2-5

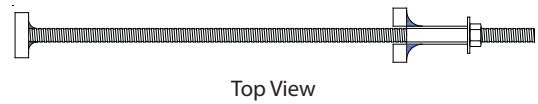

Top View



Side View

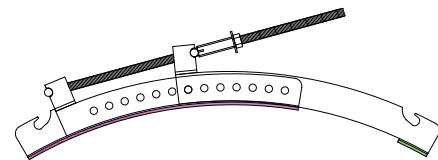

Take-Up Fixture / Tightener Assembly

3. ANCHOR POINT POSITION

- 3.1. Proper positioning of the anchor point for the hook end of the split strap is critical. If the anchor point is incorrectly positioned, the strap may not reach over the tank from one anchor point to the other, or the system may be too long for the take-up assembly.
- 3.2. The take-up assembly will adjust a total of +/- 7" to allow for variations in tank and anchor point placement. The assembly is designed so that each 1/4" of takeup of the tightener will move the slider section so that the next hole will line up with holes in the slot section for the insertion of the bolt.
- 3.3. The anchor hook point must be between 13" and 17" above the bottom of the tank
- 3.4. The split strap anchor system is designed according to tank diameter and specific placement of deadmen anchors.
 - 3.4.1. **8' Tanks (12" x 12" Deadmen)**
 - 3.4.1.1. The anchor hook point on 12" x 12" CSI supplied deadmen is 17" above the bottom of the deadman and will be at the correct position if the deadman is installed with the bottom of the deadman level with the bottom of the tank (see Figure 3-1).

Figure 3-1

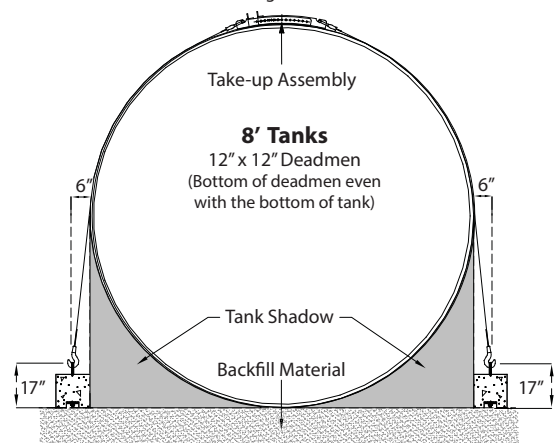

3.4.2. 6', 10', 12' Tanks (18" x 8" Low Profile (LP) Deadmen)

3.4.2.1. The anchor hook point on 18" x 8" CSI supplied deadmen is 13" above the bottom of the deadman and will be at the correct position if the deadman is installed with the bottom of the deadman level with the bottom of the tank (see Figure 3-2).

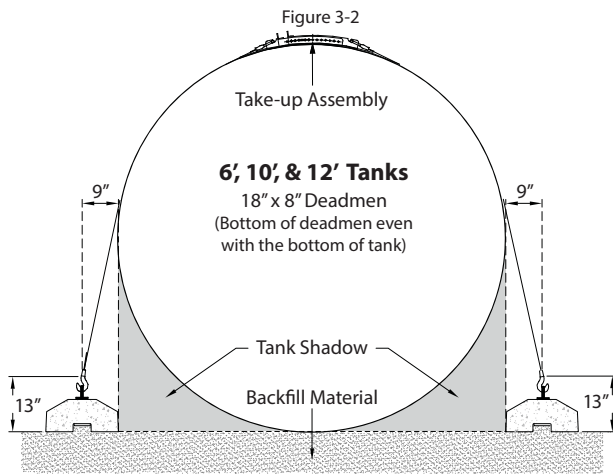

4. ANCHOR POINT DESIGN

4.1. All CSI deadmen have properly designed anchor points. If using any other mechanical anchoring other than CSI supplied deadmen, the anchor points must conform to CSI's design specifications. Refer to INST 6001 for anchor point design specifications.

5. INSTALLATION

WARNING

Use only the anchor points when lifting and positioning CSI deadmen. Failure to do so could result in death or serious injury.

- 5.1. Follow all instructions in Containment Solutions Pub. No INST 6001.
- 5.2. Insure lifting equipment is rated to handle the load before lifting. Refer to INST 6001.
- 5.3. Lift deadman using a minimum of two equally spaced anchor points.
- 5.4. The angle from the deadmen to the lifting equipment should always be between 60° and 90° (see Figure 5-1).

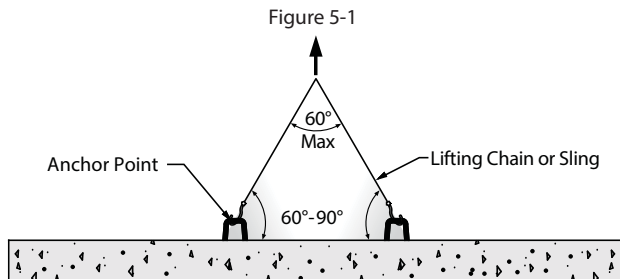

- 5.5. Anchor points must be aligned ($\pm 1"$) with tank anchor ribs designated with $\blacktriangleright \blacktriangleleft$ stenciled to the tank wall.
- 5.6. Use only 1 strap per anchor point.
- 5.7. Deadmen anchors must be placed in the excavation parallel to the tank and positioned so the inside edges of the deadmen are aligned with the tank shadow.
- 5.8. Place deadman or anchor pad in the excavation so the anchor hook point is positioned properly according to Section 3.
- 5.9. Position personnel on tank top when ready to hook straps to take-up assembly. Follow all applicable safety requirements.
- 5.10. Dangle the hook end of a strap over the tank side (with the hook facing away from the tank) and hook it into the anchor point. A person standing on an adjacent tank or outside of the excavation with a long stick will be required to assist in positioning the hook into the anchor point.
- 5.11. Secure the eye end of the strap into the slotted section of the take-up assembly centered onto the appropriate rib. Keep tension on the strap so it does not unhook from the anchor point.
- 5.12. The rubber attached to the bottom of the take-up assembly must remain in place between the take-up assembly and the rib at all times.
 - 5.12.1. The assembly pieces will both slide on top of the rib until the assembly is tight. If the rubber will not slide on the rib surface, soap the rib surface and continue.
- 5.13. Repeat on the other side of the tank.
- 5.14. Attach the tightener to the take-up assembly and remove the special bolt in the take up fixture.
- 5.15. To tighten:
 - 5.15.1. Start by turning the tightener nut until the assembly is hand tight.
 - 5.15.2. Continue tightening the nut (no more than $\frac{1}{4}"$ more) until any set of holes are aligned and a bolt could be inserted through the assembly. Mark this hole on the slot section for use in 5.15.3.
 - 5.15.3. Continue to tighten for an additional $\frac{1}{2}"$ until the second hole from the hole identified in 5.15.2. is aligned with a slot hole.
 - 5.15.4. Insert the supplied bolt.
- 5.16. After installation there must be at least 1" of clearance between any metal on the anchoring hardware, including the strap ends, and the tank. The take-up assembly rubber is sufficient clearance on the tank top. Metal should never be in contact with the tank.
- 5.17. All anchor straps should be uniformly tightened with turnbuckles. Straps should be snug, but not cause tank deflection.
- 5.18. Measure tank deflection by measuring tank diameter before and after snugging straps. The tank diameter should not change as a result of tightening the straps. If the tank diameter changes, loosen the straps.
- 5.19. Pin the take-up assembly pieces together through the aligned holes using the special bolt and washer supplied with the assembly (washer under the bolt head). Screw the nut onto the bolt to the end of the threads (the nut will not be tight against the take-up assembly). This will insure that the smooth (non-threaded) section of the bolt is under load.
- 5.20. Repeat strap assembly for remaining strap locations.
- 5.21. After hardware is installed, all exposed metal on the anchoring system should be coated or galvanized to protect against corrosion.