

DOUBLE-WALL TANK SUMPS

INSTALLATION INSTRUCTIONS & OPERATING GUIDELINES



CONTAINMENT
SOLUTIONS®

- 1. Introduction 2
- 2. Handling/Storage..... 3
- 3. Assembly Instructions 3
- 4. Adhesive & Layup Instructions..... 4
- 5. Assembled Tank Sumps..... 6
- 6. Flat Bottom Tank Sump 6
- 7. Post Assembly Test..... 7
- 8. Annular Space Monitoring..... 7
- 9. Backfill 7
- 10. Surface Slab & Tank Sump Clearances..... 8
- 11. Operating Guidelines..... 9
- 12. Reservoir Monitoring 9
- 13. Tank Sump Installation Checklist 10

1. INTRODUCTION

- 1.1. The purpose of this manual is to provide specifiers, owners and contractors with detailed instructions for installing fiberglass reinforced plastic (FRP) Double-Wall Tank Sumps.
- 1.2. Tank sump installation is a specialized business. If you do not have the proper experience and you have not completed Containment Solutions, Inc. (CSI) training for tank installation in the last 24 months, please contact a trained contractor, or call CSI for a list of trained contractors.
- 1.3. These instructions have been developed and refined from the experience of over 300,000 tank installations.
- 1.4. Proper installation is required to assure the long-term performance of CSI Storage Tanks. These instruction must be followed. Failure to comply will void the limited warranty and may cause tank failure.
- 1.5. It is the responsibility of the owner, installer and operator to understand and follow all installation requirements.

1.6. Safety

- 1.6.1. These instructions should not be interpreted in any way to put one’s health at risk, or to harm property and/or the environment.
- 1.6.2. Keep this manual available at the installation site and refer to safety procedures as needed.
- 1.6.3. The following definitions will serve as a guide when reading this manual:

⚠WARNING

Indicates a potentially hazardous situation, which if not avoided could result in death or serious injury.

⚠CAUTION

Indicates a potentially hazardous situation, which if not avoided may result in minor or moderate injury.

NOTICE

Indicates a potentially hazardous situation, which if not avoided may result in property damage.

1.7. Important Information

- 1.7.1. Proper installation of each tank sump is essential to ensure the safety of all the individuals involved in the installation; to prevent tank sump damage and/or failure, which could lead to product loss and environmental contamination; to validate the tank sump limited warranty.

1.8. Important Reminders

- 1.8.1. Tank sumps must be installed according to these instructions and NFPA 30, 30A, OSHA and all applicable Federal, State, Local, or Provincial, construction, safety and environmental codes and regulations.
- 1.8.2. Any variances or deviations which are in direct conflict with these published installation instructions must be approved in writing prior to the installation by CSI Technical Support.
- 1.8.3. The presence of any CSI representative at the job site does not relieve the contractor of responsibility to follow these installation instructions.

1.9. Tank Sump Warranty Activation

- 1.9.1. These instructions must be followed.
- 1.9.2. Installing contractor must be trained in accordance with the CSI contractor training course in effect at the time of the installation.
- 1.9.3. The Installation Checklist must be properly completed and signed by the tank owner’s representative and the installing contractor at the time of installation.
- 1.9.4. The tank sump installation checklist, these instructions, and any correspondence related to the tank sump installation must be retained by the tank owner. The checklist will be required and must be provided to CSI when making a warranty claim.
- 1.9.5. The tank sump must be continuously monitored for piping leaks using an electronic leak monitoring sensor.
- 1.9.6. The tank sump must be tested after assembly and before backfilling using the procedure described in this manual.
- 1.9.7. Tank sumps must be installed using CSI assembly kits. Failure to use approved kits will void the tank sump limited warranty.

1.10. Before You Begin

⚠WARNING

To prevent fire or explosion hazard, Containment Solutions recommends air driven tools whenever possible. Do not use electrical power tools where flammable vapors or liquids exist. Also, when electric hand tools are used, be aware of potential shock hazards. Wear protective clothing and eye protection. Do not enter tank or tank sumps unless following OSHA guidelines for confined space entry. Failure to follow OSHA guidelines could result in death or serious injury.



ASPHYXIATION



FIRE



EXPLOSION

- 1.10.1. Read, understand and follow these instructions.
- 1.10.2. Barricade the work area.
- 1.10.3. Review and prepare to complete the installation checklist as the installation progresses.
- 1.10.4. If you have questions on other tank sump installation details, call CSI Technical Support.

2. HANDLING & STORAGE

CAUTION

In freezing conditions, protect collar and tank sump from water accumulation. Freezing water may cause damage.

- 2.1. Visually inspect the tank sump components for shipping or handling damage. If damage is found, contact CSI Field Service.
- 2.2. Wear gloves.
- 2.3. Do not roll, drop, or bounce.
- 2.4. Tank sump parts and kits should be stored in upright position.
- 2.5. Set on smooth surface.
- 2.6. The tank sump must be secured to prevent damage from high winds. Proper precautions should be taken to protect adhesive channels.
- 2.7. All assembly kits (Kit-AD or Kit-LK) should be stored in a cool/dry location at 50° - 70°F. Higher temperatures will shorten shelf life. Use by expiration date shown on the box label.

3. ASSEMBLY INSTRUCTIONS

CAUTION

Tank sump must be isolated from direct traffic loading.

- 3.1. Dry fit all tank sump components prior to installation.
 - 3.1.1. Determine any length changes required to insure the minimum required clearance between the tank sump top and concrete.
 - 3.1.2. Confirm enclosure top and reservoir are level.
 - 3.1.3. Verify fill/vapor spill buckets and sensor will properly align with lid opening. This is achieved by installing the top section of the tank sump so that the reservoir opening is oriented 90° from the tank centerline (see Figure 3-1).

Figure 3-1

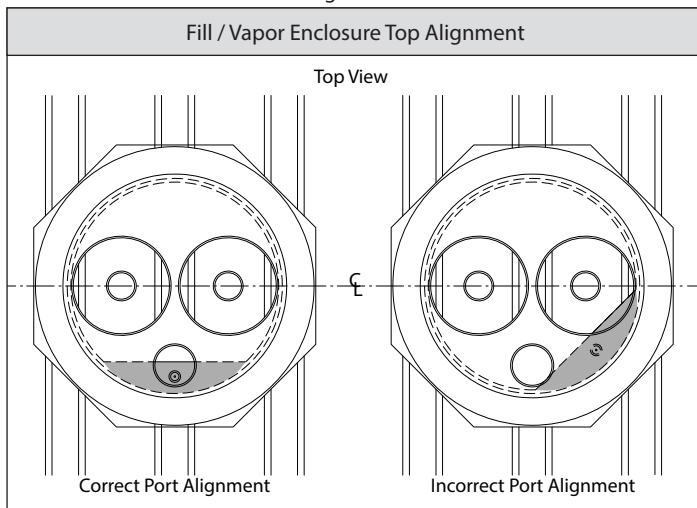

- 3.2. If required, trim tank sump body extension using a carbide tipped blade or a masonry blade. The tank sump body extension is the only component of the tank sump that can be trimmed (see Figure 3-2).

Figure 3-2

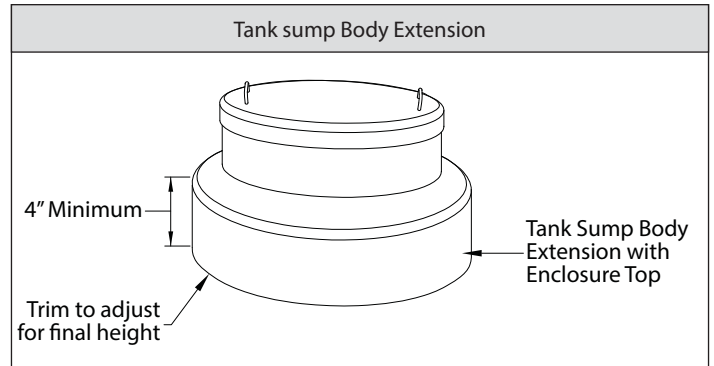

- 3.3. Field cuts must be with in $\pm 1/4$ " of square. Gaps between two joints greater than $1/4$ " must be covered with a maximum width $1/2$ " tape. This prevents resin from running into joint.
- 3.4. Maintain a minimum of 4" on the tank sump body extension to complete interior joint.
- 3.5. Even if mating surfaces have arrived from the factory abraded, the contractor must re-sand the mating surfaces within four hours of adhesive or layup application.
- 3.6. Remove any rocks, and/or debris from adhesive channel.
- 3.7. Sand and clean mating surfaces until white in color.
 - 3.7.1. Adhesive Joints - Sand the surfaces that will contact the adhesive, then wipe free of dust with a clean cloth.
 - 3.7.2. Layup Joints - Sand a minimum of 4" onto each part where the layup will be applied, then wipe free of dust with a clean cloth.
 - 3.7.3. Ensure mating surfaces are free of contaminants and dry.
 - 3.7.4. Do not use oil-based solvents, soap, or water to clean surfaces.
- 3.8. Insert channel mesh material provided with adhesive kit 360° around each joint (see Figure 3-3).

Figure 3-3

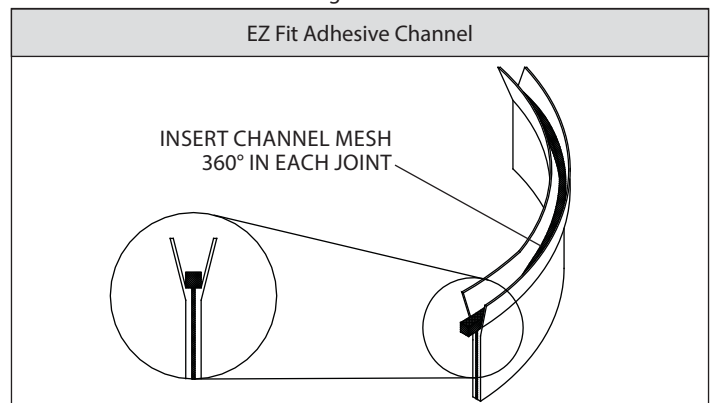

- 3.8.1. Mesh is supplied longer than required. Trim end to fit without gap or overlap.

3.9. Position tank sump on collar (see Figure 3-4).

Figure 3-4

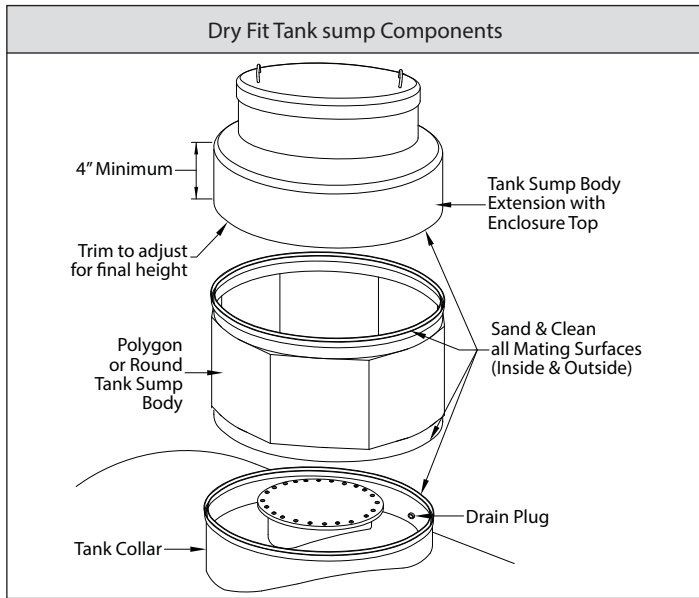

- 3.10. Use a rubber mallet, if necessary to seat tank sump on collar.
- 3.11. Confirm that surfaces and/or adhesive channels are dry and clean before mixing or applying the adhesive.
- 3.12. If the drain plug in the collar is removed, be sure the reducer fitting remains intact in the collar busing. Remove only the 1/4" drain plug.

4. ADHESIVE & LAYUP INSTRUCTIONS

⚠ WARNING

The adhesive / resin and catalyst materials and vapors are flammable. To prevent fire or explosion hazard, if a heat gun (or other ignition source) is used for supplemental heat, first evacuate flammable vapors which may accumulate in the tank sump.

Do not enter tank or tank sumps unless following OSHA guidelines for confined space entry. Failure to follow OSHA guidelines could result in death or serious injury



ASPHYXIATION



FIRE



EXPLOSION

⚠ WARNING

Always wear protective goggles and gloves when mixing and applying adhesive, resin and catalyst. The liquid materials are flammable. Keep adhesive and resin away from sparks and ignition sources.

- 4.1. CSI tank sumps must be installed using only CSI supplied assembly kits.
 - 4.1.1. Adhesive kits (Kit-AD) are used to field bond tank sump components using EZ-Fit adhesive channels.
 - 4.1.2. Layup kits (Kit-LK) are used to field bond joints without EZ-Fit adhesive channels.
- 4.2. All assembly kits (Kit-AD or Kit-LK) should be stored in a cool/dry location at 50° - 70°F. Higher temperature will shorten shelf life. Use by expiration date shown on the box.

4.3. Temperature Considerations:

- 4.3.1. After mixing adhesive and hardener, you will have no more than 20 minutes to complete the application before the resin begins to harden.
- 4.3.2. Recommended method for supplemental heat is to transfer warm air to the tank sump while keeping ignition sources away.
- 4.3.3. Cool Weather (less than 60°F):
 - 4.3.3.1. Preheat the resin or adhesive to 60-75°F.
 - 4.3.3.2. Before adhesive or layup is applied, add supplemental heat. Apply heat to keep joint surfaces over 60°F.
 - 4.3.3.3. After adhesive or layup is applied, continue to apply supplemental heat until it hardens (30 minutes minimum).
- 4.3.4. Warm Weather (between 61°F and 85°F):
 - 4.3.4.1. Adhesive or hand layup will harden in approximately 30 minutes.
 - 4.3.4.2. No supplemental heat required.
- 4.3.5. Hot Weather (above 85°F):
 - 4.3.5.1. Apply adhesive or layup more rapidly (adhesive and resin may harden in less than 10 minutes).
 - 4.3.5.2. To increase working time, cool the adhesive or resin to 60°F to slow down chemical reaction.

EZ-FIT ADHESIVE JOINTS (KIT AD)

4.4. Kit contents: This kit is designed for Adhesive Joints.

Items	Size	Qty.
Mix Instructions Sheet (INST 6051)		1
MSDS for Adhesive Kit - Part A (INST 6023)		1
MSDS for Catalyst (Cadox L-50A)		1
Putty Knife		1
Adhesive Kit - Part A	1 gal.	1
Catalyst	5 gram tubes	12
Sand Paper	36" long	1
Grout Bag		1
Mixing Stick		1

- 4.4.1. Read the following instructions completely before applying adhesive to EZ-Fit channel (see Figure 4-1).
- 4.4.2. Dry fit all tank sump components prior to sealing joints as outlined in Section 3.
- 4.4.3. Double-wall tank sump adhesive joints include two (2) EZ-Fit adhesive channels per joint, interior and exterior.
 - 4.4.3.1. 42" and 48" diameter tank sumps require (1) adhesive kit per channel, totaling two (2) adhesive kits per joint (one outside, one inside).
 - 4.4.3.2. 54" diameter tank sumps require one (1) adhesive kit per interior channel and two (2) adhesive kits per exterior channel, totaling (3) adhesive kits per joint.
- 4.4.4. Thoroughly mix two part adhesive by hand or with a power mixer following the mixing instructions contained in the adhesive kit. Pour into grout bag.
- 4.4.5. With the tank sump components in place, make two consecutive 360° passes around the tank sump, filling the adhesive channel evenly using all adhesive (see Figure 4-1).

Figure 4-1

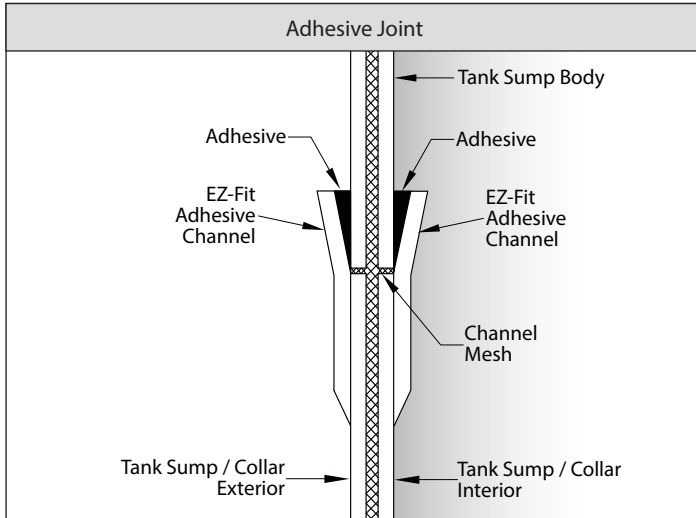

4.4.6. Allow adhesive to cure at least 5 hours without moving the joined parts. The surface of the adhesive should be hard; if not hard after 5 hours, wait up to 24 hours.

HAND LAYUP JOINTS (KIT LK)

4.5. Kit Contents: This kit is designed for Hand Layup Joints.

Box 1 of 2

Items	Size	Qty.
Pair Rubber Gloves	X-Large	1
Sandpaper	36" long	2
Plastic Roller	¾" x 3"	1
Felt Roller Handle	3"	1
Felt Roller Pad	3"	2
Chopped Strand Fiberglass Mat	6"W x 33"L	15
Wooden Mixing Stick		1

Box 2 of 2

Items	Size	Qty.
Mix Instruction Sheet (INST 6032)		1
MSDS for Layup Kit Resin - Part A (ACC 5015)		1
MSDS for Catalyst (Cadox L-50A-VR)		1
Layup Kit Resin - Part A	1 gal.	1
Catalyst (Part B)	5 gram tubes	20

4.5.1. Dry fit all tank sump components prior to sealing joints, as outlined in Section 3.

4.5.1.1. Gaps between two joints greater than ¼" must be covered with maximum width ½" width tape to prevent resin from running into joint (See Figure 4-2).

Figure 4-2

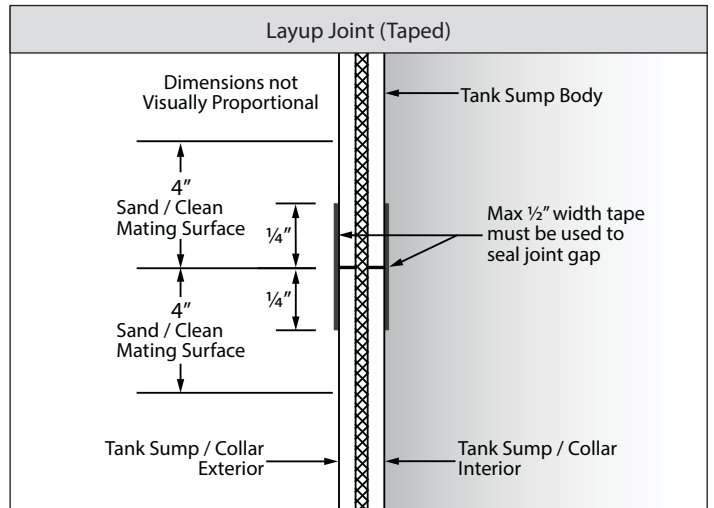

4.5.2. The tank sump will be shipped with H-clips for positioning the body on the tanks' double-wall collar. With a two (2) piece tank sump, the top is shipped with 8 additional H-clips for positioning the tank sump components.

4.5.3. Double-wall tank sump hand layup joints include both interior and exterior layups.

4.5.3.1. 42" and 48" diameter tank sumps require one (1) layup kit for the interior layup and one (1) layup kit for the exterior layup, totaling two (2) layup kits per joint.

4.5.3.2. 54" diameter tank sumps require two (2) layup kits for the interior layup and two (2) layup kits for the exterior layup, totaling four (4) layup kits per joint.

4.5.4. Thoroughly mix resin and catalyst following the mixing instructions in the layup kit.

4.5.5. Resin coat previously ground mating surfaces on tank sump with felt roller.

4.5.6. Apply 3 layers of fiberglass layup, saturated with resin, 360° around tank sump, centered on joint. All layup joints must overlap a minimum of 1" but not exceed 2" in circumferential direction (see Figure 4-3).

Figure 4-3

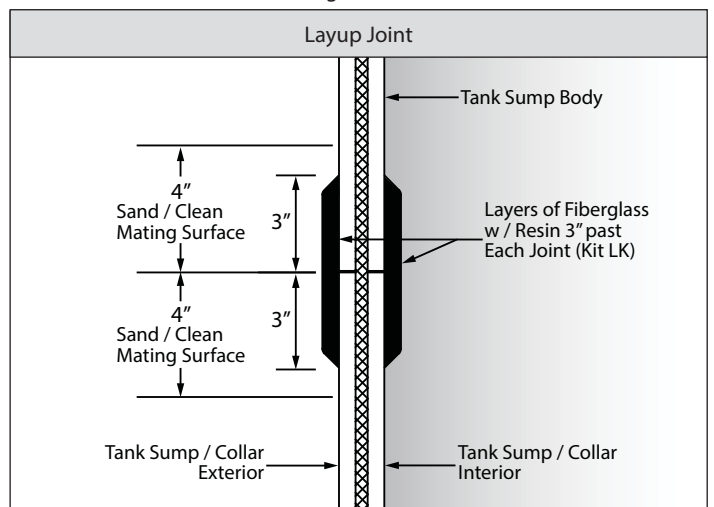

- 4.5.7. Using the ribbed roller supplied in the kit, hand roll over entire surface of layup, working air bubbles from under the fiberglass mat, especially around H-clips.
- 4.5.8. Allow layup to cure at least 5 hours without moving the joined parts. The surface of the layup should be hard; if not hard after 5 hours, wait up to 24 hours.

5. ASSEMBLED TANK SUMPS

WARNING

Failure to properly test and seal joints may result in product loss, environmental damage, explosion, or fire.

Figure 5-1

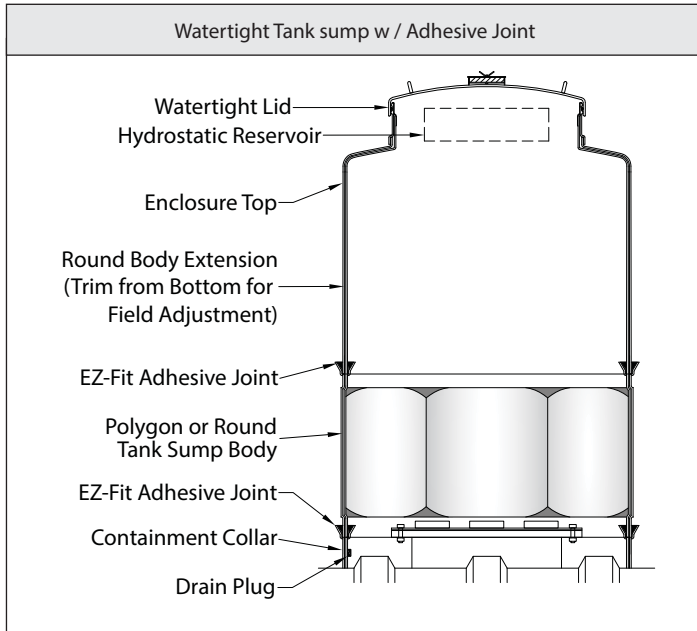
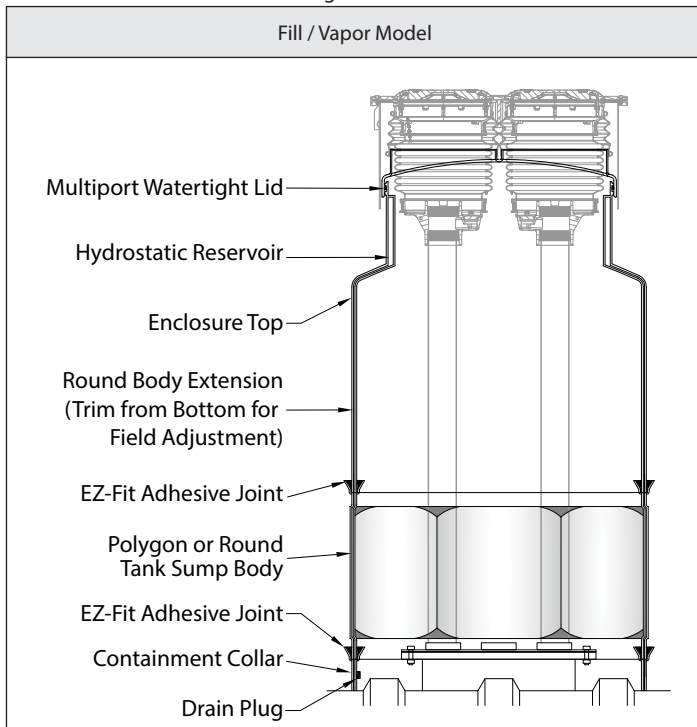
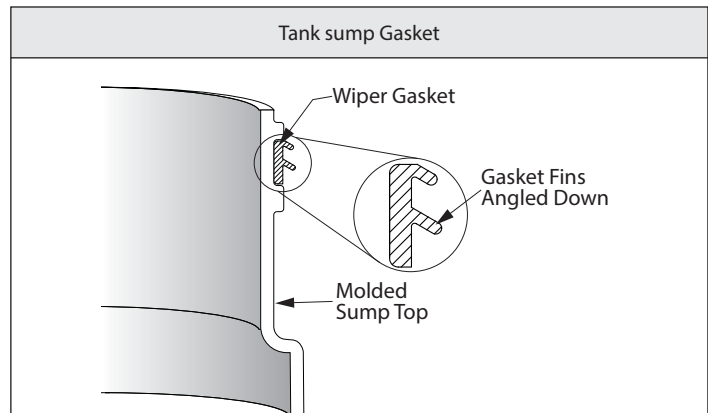

Figure 5-2



- 5.1. All joints must be sealed with CSI supplied kits.
- 5.2. All piping and electrical penetrations (supplied by others) must seal the tank sump annular space.
- 5.3. Do not connect the tank sump annular space to any other annular space.
- 5.4. Keep the tank sump lid, gasket and gasket groove free from contaminates.
- 5.5. Ensure gaskets are installed with the fins angled down, away from the lid (see Figure 5-3).

Figure 5-3



- 5.6. When installing lid, apply additional lubricant as needed.
- 5.7. If necessary, step on lid perimeter until properly seated.
- 5.8. NON-WATERTIGHT Tank sump: The lid will fit loosely on the tank sump top and will not be watertight.

6. FLAT BOTTOM TANK SUMPS

Figure 6-1

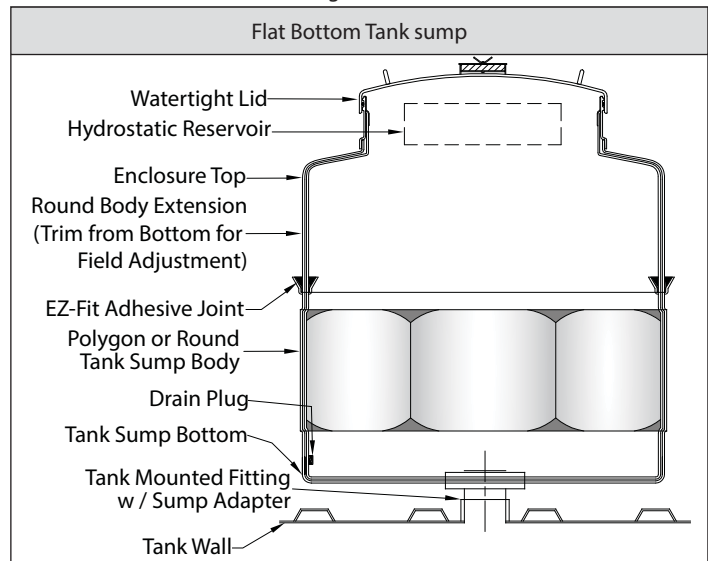

- 6.1. Follow all tank sump instructions in sections 1 - 5 for properly assembling a tank sump.
- 6.2. All joints must be sealed with CSI supplied kits.
- 6.3. Install tank fitting adapters per the manufacturers installation instructions into the tank. Prepare tank sump bottom to accept tank fitting adapters.

- 6.4. Before placing tank sump on tank fitting adapters, place approved pea gravel or crushed stone backfill between the tank top and tank sump bottom. Ensure there will be no backfill voids under the tank sump (see Figure 6-2).

Figure 6-2

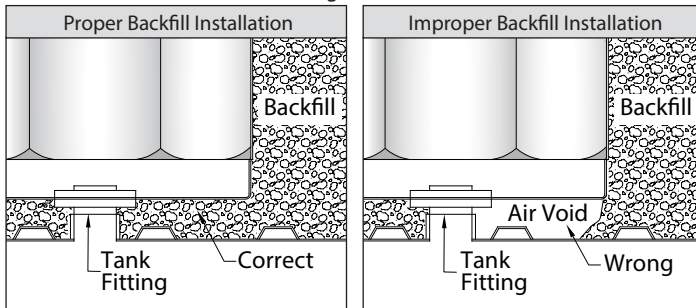

- 6.5. Position tank sump on tank fitting adapters.
 6.6. Complete manufacturers installation of tank fitting adapters.
 6.7. Do not stand in tank sump or install the tank sump lid until after the tank sump is properly backfilled and supported.
 6.8. Continue installation following these published instructions.
 6.9. Transition tank sumps are installed in exactly the same manner as a flat bottom tank sump without installing a tank fitting adapter.

7. POST ASSEMBLY TEST

- 7.1. The annular space may be pressure tested to a maximum of 3 psig during the installation.
 7.2. Prior to pressurizing the tank sump, install a 15 psi air gauge with ¼ or ½ lb. increments.
 7.3. After pressurizing, apply a soap and water solution to the entire surface area on the inside and outside of the tank sump.
 7.4. Carefully inspect for leaks as indicated by continuous formation of bubbles.
 7.5. Maintain test pressure and continue inspection for 30 minutes. Then release pressure.

8. ANNULAR SPACE MONITORING

VACUUM MONITORED ANNULAR SPACE

- 8.1. Vacuum monitoring may be used on the CSI double-wall tank sump utilizing the factory installed fitting.
 8.1.1. Maximum continuous vacuum level shall not exceed 5 psig (10.2 "Hg).
 8.1.2. Monitoring the annular space with continuous positive air pressure is not permitted.

HYDROSTATIC MONITORING

NOTICE

Hydrostatic monitoring space between the inner and outer tank sump must be vented to the atmosphere. If unvented, pressure buildup can cause tank sump damage.

- 8.2. Monitoring solutions available with biodegradable green tint.

- 8.2.1. Brine - calcium chloride in water.
 8.2.2. Propylene Glycol Solution in water.

- 8.3. Filling Tank Sump Annular Space:

- 8.3.1. Monitoring Fluid Fill Kit (MFFK Kit) is required when filling the annular space of double-wall tank sumps with monitoring fluid. Failure to use the MFFK Kit may result in entrapped air and false alarms.

- 8.3.2. MFFK Kit Contents

Items	Qty.
1½" PVC threaded fill fitting with 2 short hoses and barbed hose connectors.	1
Siphon gun	1
8' long ¾" OD by ¼" ID plastic tubing.	1
4' long ¾" OD by ¼" ID plastic tubing.	1

- 8.3.3. Remove the permanent 1½" reservoir plug from tank sump reservoir and set aside for later use.
 8.3.4. Install and hand tighten the 1½" PVC fill fitting into the tank sump reservoir coupling. No thread dope or Teflon tape is required (see Figure 8-1).

Figure 8-1

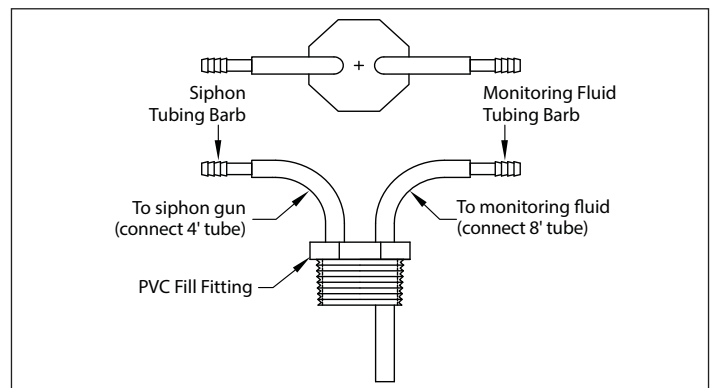

- 8.3.5. Connect the 8' plastic tubing to the monitoring fluid tubing barb and place the opposite end of the tubing in a bucket of monitoring fluid. Temporarily attach the tubing to the bucket to keep the end positioned at the bottom of the bucket.
 8.3.6. Connect the 4' plastic tubing to the siphon tubing barb and connect the opposite end to the siphon connection on the siphon gun.
 8.3.7. Connect the siphon gun to an air compressor. Regulate the supplied air pressure to not exceed 100 psi. Typical air consumption is 13.7 scfm at 100 psi.

- 8.4. Fill the tank sump in the following order:

- 8.4.1. Prepare the required gallons of monitoring fluid for each tank sump.

Tank Sump Total Height	Minimum Gallons of Monitoring Fluid Required		
	42" Tank Sump	48" Tank Sump	54" Tank Sump
4'	7	8	10
5'	8	10	11
6'	9	11	13
7'	10	12	14

- 8.4.2. Press and hold the siphon gun trigger to begin fluid filling.
- 8.4.3. As the fluid level drops in the bucket, add fluid as needed to keep fluid level above the hose end.
- 8.4.4. When the monitoring fluid reaches the fill line on the reservoir, release the siphon gun trigger.
- 8.4.5. When the vacuum is stopped, the fluid level in the reservoir will drop as the tank sump walls stabilize. Manually top off reservoir with monitoring fluid to the fill line as indicated on the reservoir.
- 8.4.6. Wait until the fluid level in the tank sump stops changing (24 hours is recommended) and then top off the reservoir. The desired final monitoring fluid level is 1½" in depth measured from the inside bottom of the reservoir. This level is also indicated on the reservoir label.
- 8.4.7. Remove the PVC fill fitting, insert the single point float sensor and re-install the 1½" permanent reservoir plug. Be sure the reservoir plug has at least a ⅛" diameter hole in the top of the plug or around the wire for venting of the reservoir. Do not caulk or otherwise seal the vent space between the wire and the fitting hole.

9. BACKFILL

- 9.1. The use of approved backfill material is critical to long term tank sump performance. Failure to use approved backfill may result in tank sump failure and will void the limited warranty (see Figure 9-1).

Figure 9-1

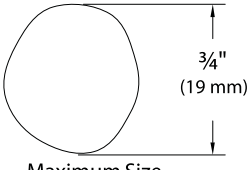
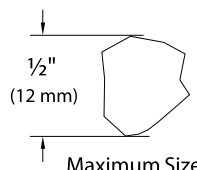
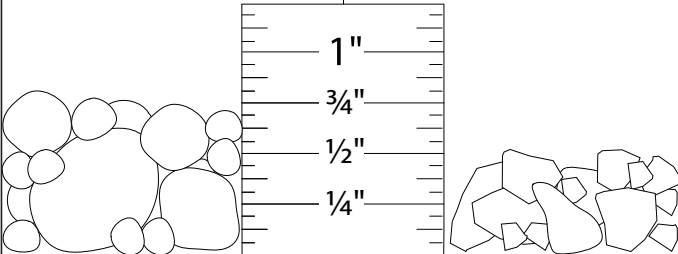
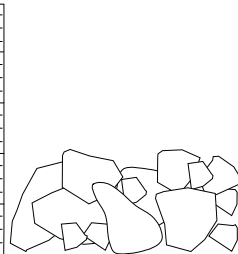
PEA GRAVEL	CRUSHED STONE
 <p>Maximum Size</p>	 <p>Maximum Size</p>
	
<p>Pea Gravel: Clean naturally-rounded aggregate with particle sizes no larger than ¾" with no more than 5% passing a #8 sieve. Dry density must be a minimum of 95 pounds per cubic foot.</p>	<p>Crushed Stone or Gravel: Washed, with angular particle sizes no larger than ½" with no more than 5% passing a #8 sieve. Dry density must be a minimum of 95 pounds per cubic foot.</p>

- 9.2. Replace all excavated native soil with approved backfill of proper sized and gradation. Use backfill which meets ASTM C-33 for quality and soundness.
- 9.3. Require your backfill supplier to certify that the backfill meets this specification.
- 9.4. Keep backfill dry and free of ice in freezing conditions.
- 9.5. For alternative backfill for tank sumps, other than what is specified in Figure 9-1, refer to INST 6060.
- 9.6. To help insure proper backfill material size, CSI offers an Approved Backfill Calculator available on our website: www.containmentsolutions.com, under "Service Training and Support", then "Tank Support Calculations".

10. SURFACE SLAB & TANK SUMP CLEARANCES

- 10.1. Isolate all tank sumps from direct traffic loading.
- 10.2. After backfilling to top of tank sump:
 - 10.2.1. Backfill around tank sump top to a level 3" above the horizontal position of the enclosed top. Place a 5' x 5' x ¾" rigid board with hole on backfill to support concrete and provide a channel for water runoff (see Figure 10-1).

Figure 10-1

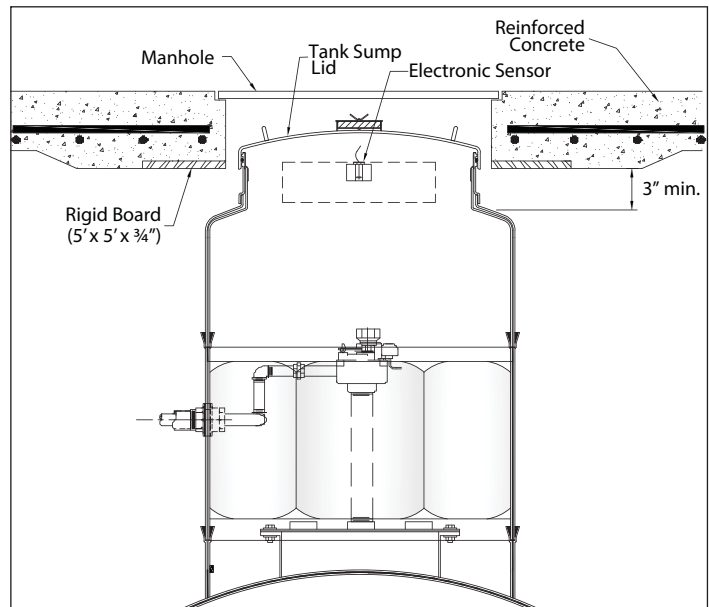

- 10.2.1.1. Use a grade access manhole large enough to allow tank sump lid removal after installation.
- 10.2.2. Adequate clearances must be maintained between the tank sump lid and manhole lid to prevent the direct transfer of traffic load to the tank sump.
- 10.2.3. Pour slab directly onto rigid board.
- 10.2.4. If the tank sump is located in a traffic area, the concrete traffic pad, reinforcement and thickness must be designed for job conditions and traffic loads to assure concrete traffic pad integrity. It is the responsibility of the tank owner or tank owner's representative to design the traffic pad for all loads.

11. OPERATING GUIDELINES

- 11.1. The tank sump installation checklist, these instructions, and any correspondence related to the tank sump installation must be retained by the tank owner. The checklist will be required and must be provided to CSI when making a warranty claim.
- 11.2. For the life of the installation, the installed tank sump must comply with NFPA (30, 30A and 31) and all applicable Federal, State, Local or Provincial codes and regulations.
- 11.3. It is the responsibility of the tank sump owner/operator to follow these instructions and operating guidelines and all limitations as stated in the limited warranties in effect at time of delivery.
- 11.4. The limited warranty in effect at the time of tank sump delivery will apply and is available online at www.containmentsolutions.com.
- 11.5. Tank sump entry is considered a confined space entry.
- 11.6. The tank sump owner should not allow anyone other than properly trained and equipped personnel to enter a tank sump.
 - 11.6.1. Proper permits and industry accepted minimum standards must be followed before anyone can enter a tank sump.
 - 11.6.2. Contact Containment Solutions Field Services at (800) 822-1997 if repairs or modifications are required.
- 11.7. Tank sump entry by unqualified personnel can lead to fire, explosion, asphyxiation and/or death. Tank sumps are for use by qualified personnel with proper training and safety equipment.

!WARNING

Do not enter tank or tank sumps unless following OSHA guidelines for confined space entry. Failure to follow OSHA guidelines could result in death or serious injury.



ASPHYXIATION



FIRE



EXPLOSION

- 11.8. Do not attempt to repair or modify your tank sump. Any repairs or modifications will void the tank sump limited warranty.
- 11.9. If tank sump entry is required for repairs or modifications or inspections, contact Containment Solutions Field Services at (800) 822-1997.

- 11.10. The tank sump must be continuously monitored with an electronic leak detector for potential spills or leaks.
- 11.11. Tank owner/operator must leak test the collar and tank sump after any damage, repairs or modifications. All regulatory testing requirements must be followed.
- 11.12. The gasket is a consumable product which will have to be replaced periodically or when it shows a leak during a tightness test.
 - 11.12.1. Ensure gasket is installed per instructions in Section 5, 5.3 and Figure 5-2.
- 11.13. The gasket lubricant will require periodic replacement as it will degrade over time. Any lubricant that will not dissolve in gasoline or water, and not attack Buna_N rubber is acceptable. While not as long lasting, other lubricants like barium grease or petroleum jelly can also be used.
- 11.14. Remove the tank sump lid by using one handle along the edge of the lid.

12. RESERVOIR MONITORING

- 12.1. If the reservoir sensor indicates an alarm condition, it is necessary to first determine that the reservoir is level and that the alarm is not the result of an incorrect initial fluid level setting.
 - 12.1.1. Remove the sensor.
 - 12.1.2. Test the sensor for proper operation.
 - 12.1.3. Reset the fluid level in the reservoir by adding or removing fluid. The proper monitoring fluid level in the reservoir is 1½" from the inside bottom of the reservoir.
 - 12.1.4. Reinstall the sensor and check for level. Ensure sensor is level and sitting on reservoir bottom.

13. TANK SUMP INSTALLATION CHECKLIST

- 13.1. The installation checklist in this manual must be properly completed, signed by the tank owner's representative and the installing contractor.
- 13.2. The tank sump installation checklist, these instructions, and any correspondence related to the tank sump installation must be retained by the tank owner. The checklist will be required and must be provided to CSI when making a warranty claim.
- 13.3. Double-wall tank sump installation check list is on next page.

Field Service Dept.
Mt. Union, Pennsylvania
(800) 822-1997 • (814) 542-8520



Technical Support
Conroe, Texas
(800) 537-4730 • (936) 756-7731

DOUBLE-WALL TANK SUMP INSTALLATION CHECKLIST

For Fiberglass Tank sumps

The tank sump installation checklist, these instructions, and any correspondence related to the tank sump installation must be retained by the tank owner. This checklist will be required and must be provided to CSI when making a warranty claim.

Site Owner _____ Date of Installation _____

Site Address _____
Street City State Zip

Installing Contractor _____
Company Street City State Zip

Double-Wall Tank sump	Initial On Lines Below
-----------------------	------------------------

Completed

1. All tank sump components have been inspected for damage prior to installation. _____
2. All tank sump parts and components were handled and stored according to these instructions. _____
3. All joints have been prepared per these instructions. (check one below) _____
 EZ-Fit Adhesive Joints (KIT AD) Hand Layup Joints (KIT LK) Both
4. Date on Assembly Kit Box _____ Date kit used _____
5. All joints were given a minimum of 5 hours to cure without parts being moved or disturbed. _____
6. Tank sump tops are properly protected from traffic load. _____
7. Approved backfill was used around and under the entire tank sump. _____
8. Gaskets are lubricated, clean, and undamaged. Finned gaskets have fins pointing down. _____
9. Tank sump with Fill/Vapor lid is oriented so that the reservoir opening is 90° from tank centerline. _____
10. All tank sump annular spaces were pressure / soap tested for tightness prior to backfilling. _____
11. If monitoring fluid was added to the annular space, confirm that the CSI MFFK kit was used. _____
12. Diameter and quantity of tank sumps installed and tested. _____
 42" _____ qty. 48" _____ qty. 54" _____ qty.

Installation was in accordance with most recent CSI Installation Instructions Pub. No. INST 6034.

Owner Representative (Print Name)	Date	Contractor Representative (Print Name)	Date
-----------------------------------	------	--	------

Owner Representative (Signature)	Contractor Representative (Signature)
----------------------------------	---------------------------------------



CONTAINMENT
SOLUTIONS®

5150 Jefferson Chemical Road Conroe, Texas 77301-6834
 Tel: 936-756-7731 Fax: 936-756-7766
 www.containmentsolutions.com

Copyright © 2015 Containment Solutions, Inc. • All Rights Reserved • June 2015 • Pub. No. INST 6034G

Technical Support

(800) 537-4730

Fax: (936) 756-7665

Field Service

(800) 822-1997

Fax: (814) 542-5020

Tank Sales

(877) 274-8265

Fax: (936) 756-7665



CONTAINMENT
SOLUTIONS[®]

5150 Jefferson Chemical Road • Conroe, TX 77301-6834

Phone: 936-756-7731 • Fax 936-756-7766

www.containmentsolutions.com