

FLOWTITE PRODUCTS

GREASE INTERCEPTOR

NOTE: CUSTOMER SUPPLIED
"ASTM C-1644" APPROVED
FLEXIBLE PIPING COUPLING
REQUIRED ON TANGENTIALLY
MTD. NOZZLES, & PIPES

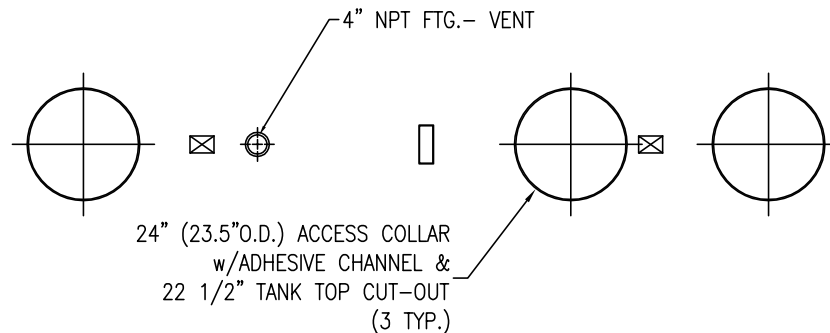

SHELL CODES: 2-E4S101S2
THIS IS AN IAPMO APPROVED TANK
COMPLIANCE STANDARDS AND CODES:
IAPMO/ANSI Z1001
UNIFORM PLUMBING CODE (UPC)
INTERNATIONAL PLUMBING CODE (IPC)
MFG. PER PE-C22.85

CAPACITIES:
LIQUID OPERATING CAPACITY = 1343 GALS
FREE SURFACE AREA OF LIQUID = 46 SQ/FT
GREASE/FOG STORAGE = 548 GALS/4165 LBS

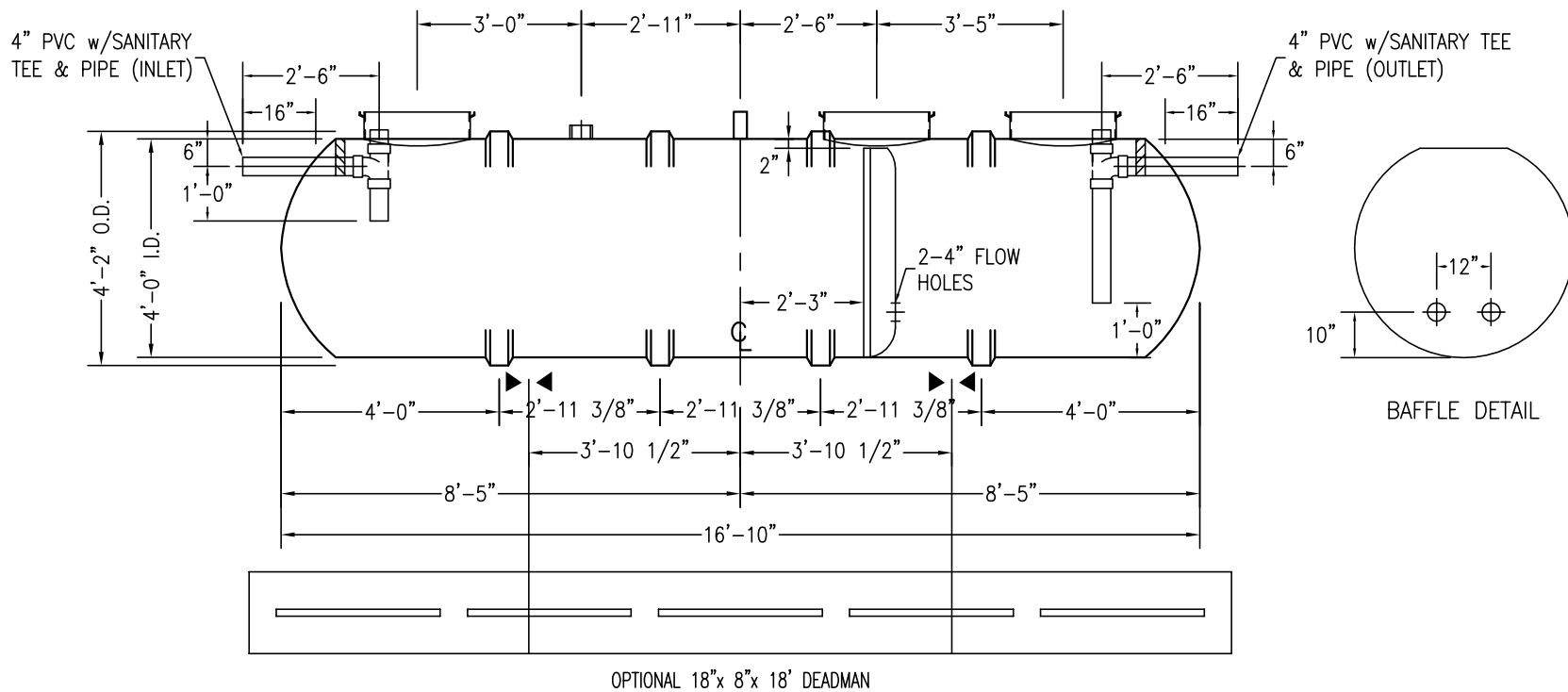

- NOTES:
- ☒ HOLD DOWN STRAP CLIP
 - ▶◀ HOLD DOWN STRAP LOCATION
 - TYPE "13" LIFT LUG - SD
 - TYPE "13" LIFT LUG - HD

SWT D5 (4')-1300 2B-IG		DATE:	1/1/2014
IAPMO GREASE INTERCEPTOR		DRAWN BY:	K.A.SOEDER
CONTAINMENT SOLUTIONS	CAPACITY:	REVISION:	02/01/17-A
	WEIGHT: DRY/WET	DWG NUMBER:	413CSW-IG
	1,514		
	725		