

Rainwater Harvesting Aboveground Tank Model RWH (54) 700

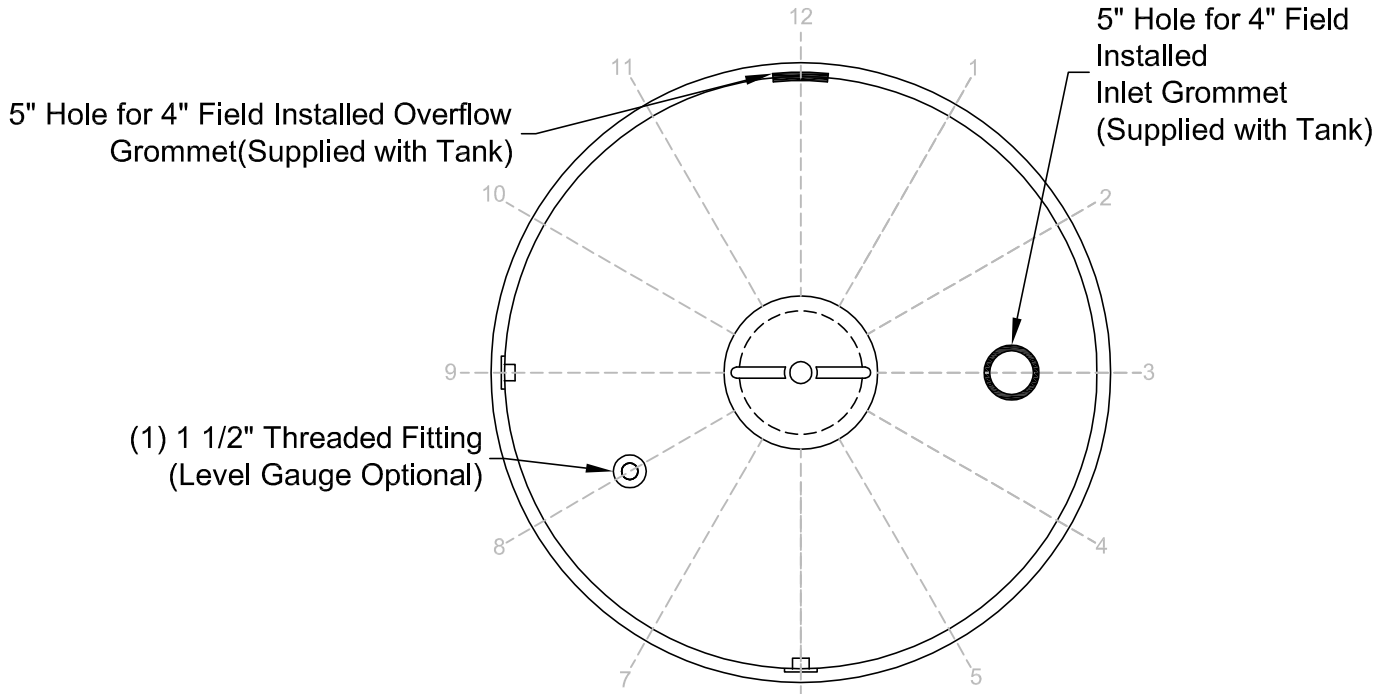

TOP VIEW

14" O.D. Access Lid
(11 1/4" I.D. Opening)

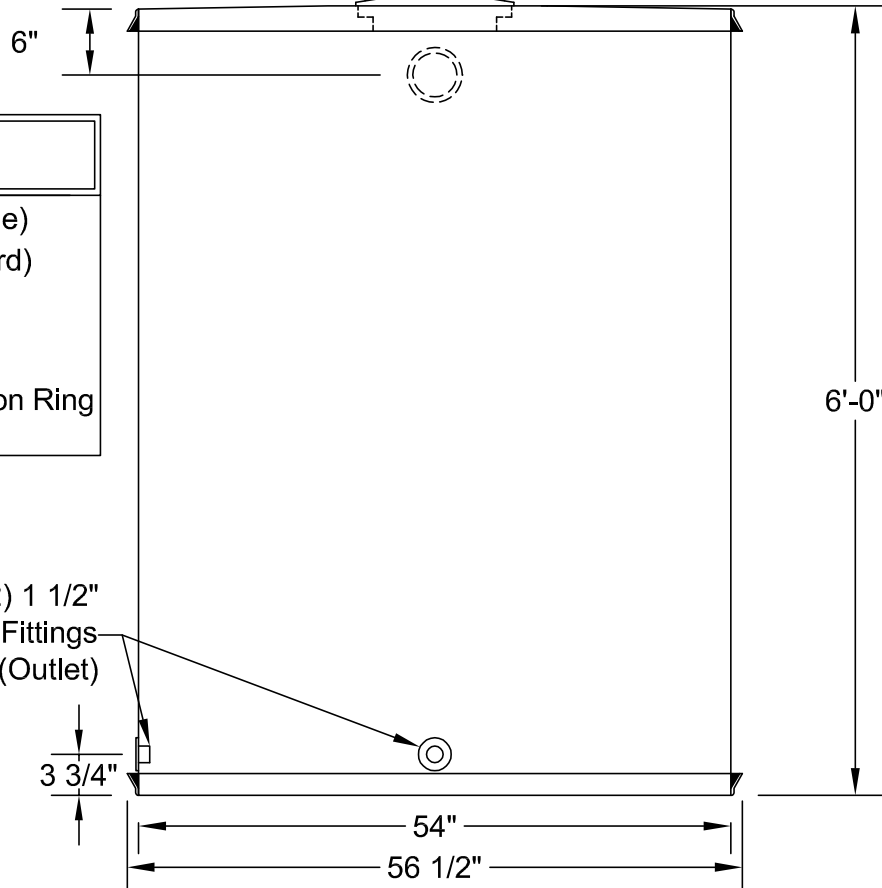

ELEVATION VIEW

SEE SPEC #PE-C45.03

Available Finishes (Choose One)

- Natural Fiberglass (Standard)
- Desert Sand
- Forest Green
- 60" dia x 6" Long Foundation Ring (Same Finish as Tank)



CONTAINMENT SOLUTIONS

CUSTOMER		RWH AGT (54) 700 Gallons				DATE: 7/1/2010
APPROVAL SIGNATURE:	SIGNATURE DATE:	NOM. WEIGHT: 220 LBS.	DRAWN BY: J.HARMON	REV #: B	REV DATE: 1/1/2014	REV BY: RSO
						DWG NUMBER: RWH AGT(54)-700