

FLUID ELECTRONICS

COLLAR, BULKHEAD, SUMP FLOAT SWITCH

MODEL FCBS 700

1. GENERAL DESCRIPTION

1.1. Containment Solutions provides a Fluid Electronics float switch sensor (FCBS 700) that is designed to monitor for the presence of liquid within a normally "dry" environment. The sensor can not distinguish between water and hydrocarbon. It must be installed in the "Vertical" position in containment collars of fiberglass tanks, bulkhead spaces, interstitial monitoring tubes, oil pans and tank sumps. It consists of a single float, on a stem, and actuates in the presence of 1/2" of liquid. The FCBS 700 sensor interfaces with CSI's Fluid Electronics family of control panels, or with most control panels manufactured by other vendors.

2. FEATURES

- 2.1. The FCBS 700 Non-discriminating "Dry" Float Switch Sensor is a float actuated sensor designed for installation in a Vertical position. The compact size of the assembly and favorable displacement properties of the float make this sensor ideal for monitoring shallow liquid levels.
- 2.2. The sensor assembly may be suspended at the desired point of actuation with a mounting clip, with the sensor cable and compression fitting or reducer bushing, or allowed to rest at the bottom of the monitoring area.
- 2.3. The sensor assembly is cylindrical in shape. It is compact (1.125" diameter x 4" high) and easy to install. The sensor may be located up to 5000 feet from a CSI Fluid Electronics control/alarm panel.
- 2.4. The assembly consists of a single Buna-Nitrile float that is compatible with nearly all chemical and petrochemical applications. The float stem is constructed of brass and contains a single reed switch that is opened by the movement of the float over the switch. A stainless steel housing protects the float and stem from damage.
- 2.5. The FCBS 700 float sensor is intended to be used in conjunction with one of the following control/alarm panels:
 - 2.5.1. Fluid Electronics (CSI) - CPF 1, 2, 3 & 4.
 - 2.5.2. Pneumercator - LC 1000, E700-1, LDE-700, or LDE-740.
 - 2.5.3. Veeder Root - TLS 250 or TLS 350.

Figure 2-1

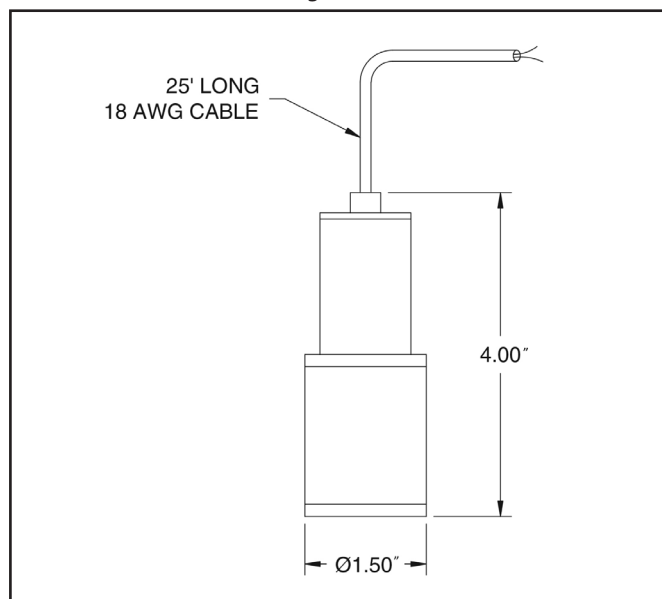

3. SENSOR OPERATION

3.1. The FCBS 700 float sensor is designed for "Vertical" installation in the containment collars of double-wall fiberglass tanks, bulkhead spaces, interstitial monitoring tubes, oil pans and tank sumps. The sensor consists of a float assembly that allows a single float to pass over a single reed switch as the liquid level rises 1/2" above the base. As the float passes over the switch, the circuit is opened and a signal is sent to the control panel indicating an alarm condition. The normal operating conditions of the monitoring areas for which the FCBS 700 is intended is DRY. Any liquid present in these areas indicates a piping or submersible pump leak may have occurred and further investigation is recommended.

4. SPECIFICATIONS

Float	Buna-Nitrile
Float Stem	Brass
Connector Cable	2 Conductor 18 AWG 10' Length, PVC Coated
Power Source	Provided by Alarm Panel
Sensor Housing	1.125" Dia. x 4" Height Stainless Steel Construction
Sensor	Reed type Switch
Alarm Set Point	1/2" from Base
Temperature Range	-40° F to 160° F (-40° C to 71° C)
Pressure	Full Vacuum to 100 PSI

5. INSTALLATION

5.1. For detailed information on the installation and wiring of this sensor, see CSI's Fluid Electronics' Installation and Operations Manual for the appropriate control panel.

SENSOR PLACEMENT

5.2. The FCBS 700 float sensor is intended for placement in containment collars, bulkhead spaces, interstitial monitoring tubes, oil pans and tank sumps to monitor for the presence of liquid. The sensor assembly must remain in the vertical position for proper operation. Placement of the sensor is accomplished by either attaching the sensor to a "mounting clip" or by suspending the sensor by the connecting cable from a compression fitting in a riser cap or reducer bushing.

5.3. Clip or Collar Mounting (See Figure 5-1)

- 5.3.1. Insure the area to be monitored is free of all fluids. If any fluid is present, remove and dispose of properly.
- 5.3.2. Attach the sensor cable to the wire coming from the alarm panel. This connection must be made in an acceptable electrical junction box (supplied by contractor), see the Wiring Instructions listed below.
- 5.3.3. Once the wiring connections have been completed, but before attaching the sensor to the contractor supplied mounting clip, follow the testing procedures listed in Section 6.
- 5.3.4. Upon verifying that the sensor operates correctly, attach the sensor to the mounting clip by using an adjustable hose clamp.

5.3.5. Check the alarm panel to determine if the status lights are working correctly.

Figure 5-1

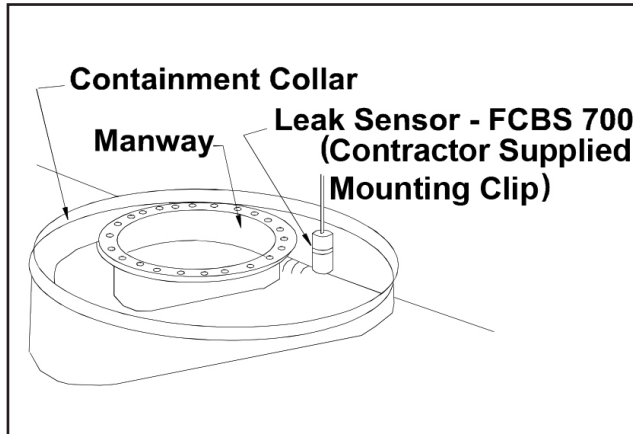

5.4. Suspension Mounting (See Figure 5-2 & Figure 5-3)

- 5.4.1. Insure the area to be monitored is free of all fluids. If any fluid is present, remove and dispose of properly.
- 5.4.2. If a Riser Pipe is required to access the monitoring area proceed to Section 5.4.3, otherwise proceed to Section 5.4.4.
- 5.4.3. Attach the riser pipe (provided by others) to the NPT fitting provided for installing the leak sensor within the monitoring area. Petroleum compatible pipe dope should be applied on all threads. The riser pipe should be cut so that, when fully assembled it and the leak sensor assembly do not apply any pressure on the tank, containment collar, bulkhead space or tank sump. They should also not extend above grade in an underground installation.
- 5.4.4. Measure the mounting height (the distance from the top of the opening to the bottom of the space to be monitored).
- 5.4.5. Unroll the sensor/cable assembly. Measure from sensor's bottom up the cable until reaching the cable measurement (from Section 5.4.4) and mark the cable at that point.
- 5.4.6. Feed the cable through the bottom of the riser cap until you see the mark on the cable. Insert the sensor and cable through the tank opening.
- 5.4.7. Tighten the compression fitting with the cable mark in the correct position.
- 5.4.8. Attach the sensor cable to the alarm panel wire in an acceptable electrical junction box (supplied by others), see the Wiring Instructions listed below.
- 5.4.9. Once the wiring connections have been completed, but before locking the sensor into position, lower the sensor, through the riser pipe, into the desired location in the monitoring area. Insure that the sensor remains in the vertical position.
- 5.4.10. Place the riser cap onto riser pipe.
- 5.4.11. Check the alarm panel to determine if the status lights are working correctly.

Figure 5-2

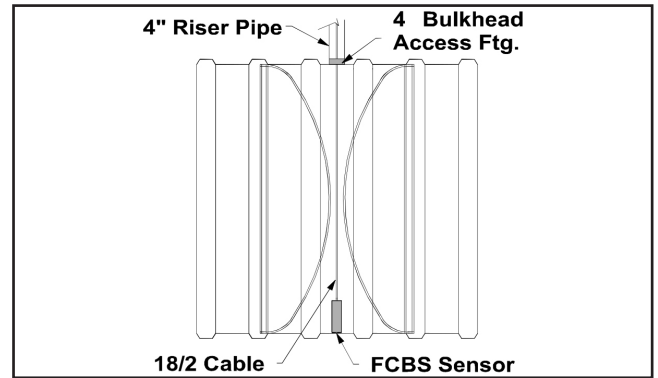
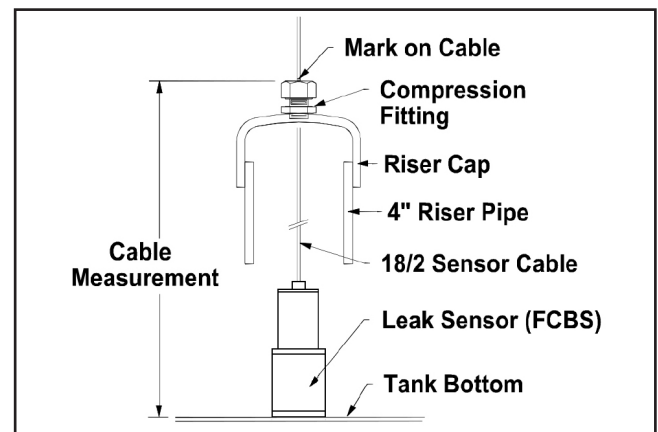

Figure 5-3



WIRING

- 5.5. The sensor is wired differently for various alarm panels and must be connected correctly with the alarm panel in order for the system to operate properly. See the control panel manufacturer's instructions for the type of wire to be used and for the most recent wiring diagrams. All conduit and electrical junction boxes must be watertight to prevent intrusion of groundwater or rainwater from entering conduits and junction boxes. Ensure that wiring meets all local, state and national codes.
- 5.6. Fluid Electronics CPF 1, 2, 3 & 4 (See Figure 5-4).
- 5.7. Pneumercator LC 1000, LDE 700, or LDE 740 (See Figure 5-5).
- 5.8. Veeder Root TLS-250 or 350 (See Figure 5-6).

Figure 5-4

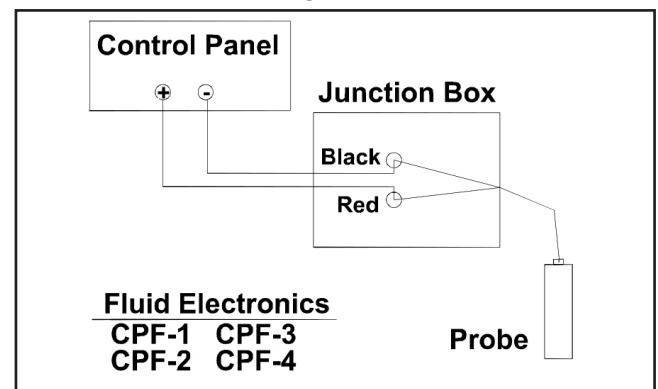

Figure 5-5

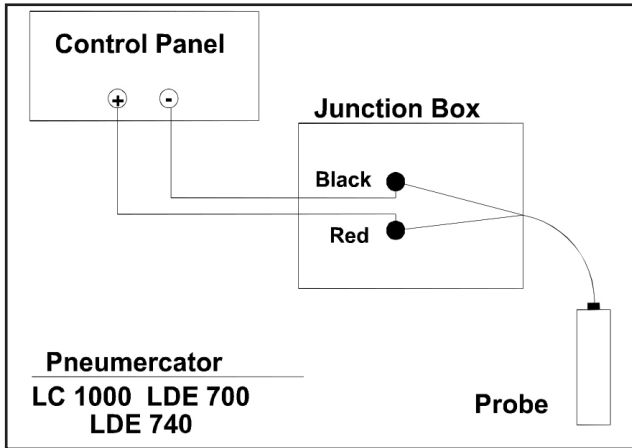
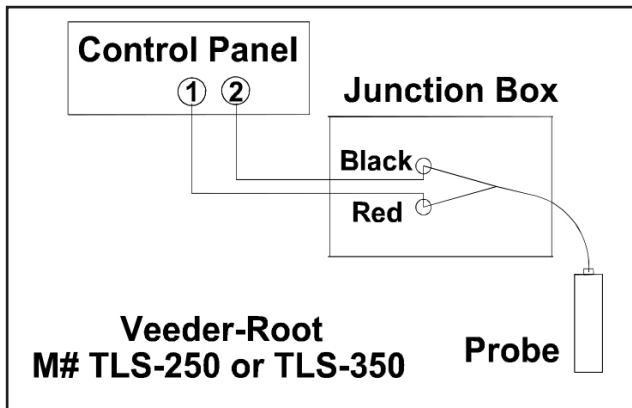

Figure 5-6



6. SENSOR TESTING AND MAINTENANCE

- 6.1. The sensor consists of a single reed switch and float installed within a sensor housing. The actuation point is located 1/2" off the base of the housing. To determine if the float switch is functioning properly these steps must be followed prior to installation, at least annually or when an alarm condition exists:
- 6.2. Prior to Installation
 - 6.2.1. Connect the sensor to the control panel according to Section 5. The alarm panel should be in the normal operations mode.
 - 6.2.2. Fill a bucket with water to a height of 1".
 - 6.2.3. Place the sensor in the bucket. The control panel should be reporting an alarm condition. The red alarm indicator should be illuminated and the buzzer should be sounding.
 - 6.2.4. The sensor is ready for installation according to Section 5.
- 6.3. Periodic Testing
 - 6.3.1. The alarm panel can be in either the normal operations mode or an alarm condition during this test procedure.
 - 6.3.2. Fill a bucket with water to a height of 1".
 - 6.3.3. Remove the sensor from the monitoring area. The alarm panel should be in the normal operations mode. Place the sensor in the bucket. The control panel should be reporting an alarm condition. The red alarm indicator should be illuminated and the buzzer should be sounding.
 - 6.3.4. Reinstall the sensor according to Section 5.