

**NOTE:**  
 OVERALL SHIPPING DIMENSION: 10'-4" L X 3'-11" W X 3'-11" H

ITEM	SIZE	SUGGESTED FUNCTION
1	4"	EFFLUENT
2	4"	INFLUENT
3	4"	TRANSFER PIPE
4		COALESCER
5		DEBRIS PLATES
6	2" X 6"	OIL EQUALIZING ORIFICE
7		COVER, DWG."CVB004"
8	1"	FLOAT SENSOR NPT FTG.
9	2"	OIL DRAW W/PIPE

**TANK SPECIFICATIONS**  
 MATERIAL: PRIMARY TANK - 10 GA.

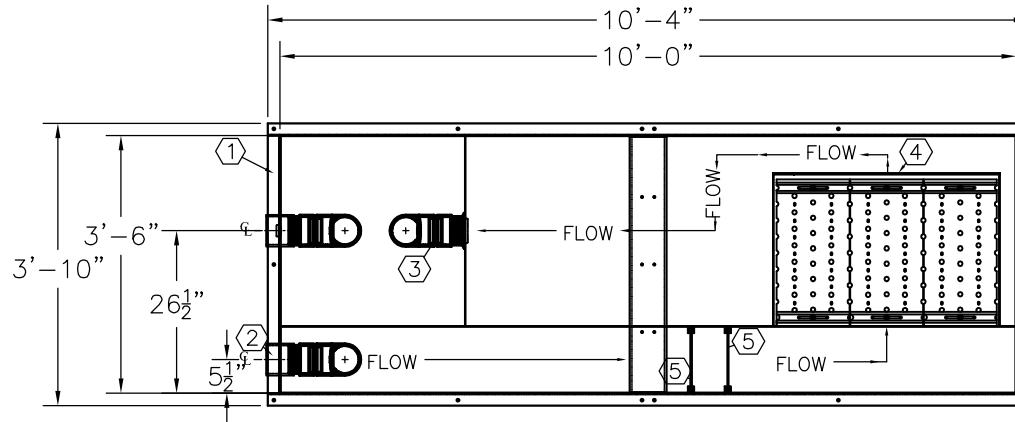

**TOP VIEW**  
 TOP COVER REMOVED FOR CLARITY  
 REFER TO DWG. "CVB004" FOR COVER DETAIL

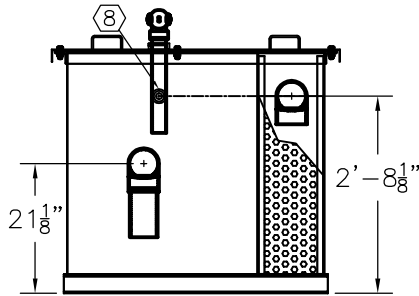

**LEFT END VIEW**

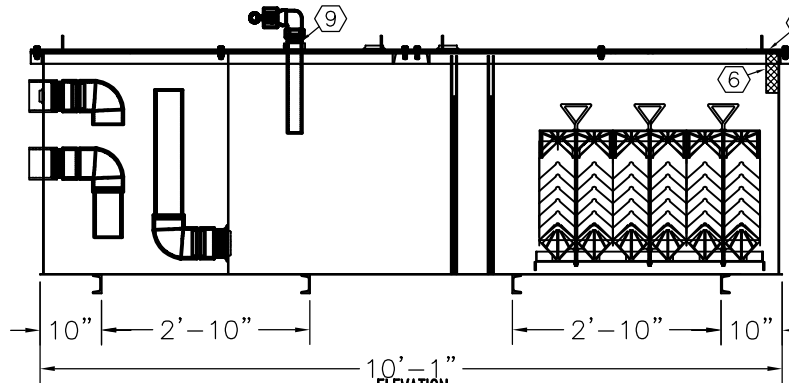

**ELEVATION**  
 FRONT FACE & BHD REMOVED FOR CLARITY

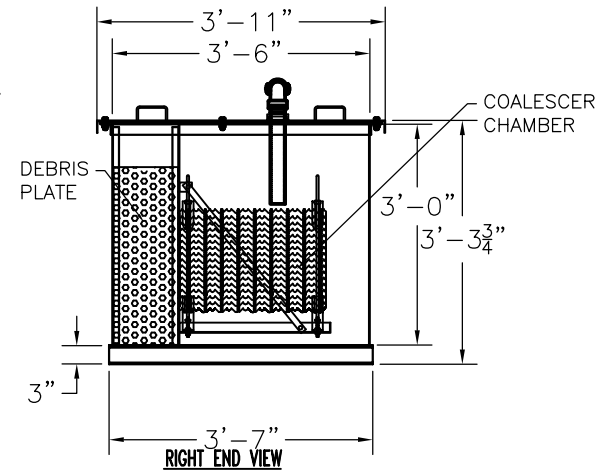

**RIGHT END VIEW**

PRODUCT CODE	GALLONS	DESCRIPTION	OVERALL SIZE	SHIP WT.
WSAA1750SS000	750	SINGLE WALL OIL WATER SEPARATOR (75 GPM)	10'-1" L X 3'-7" W X 3'-4" H	2,100 LBS.

THIS DRAWING AND DESIGN SHOWN HEREIN IS THE PROPERTY OF CONTAINMENT SOLUTIONS. USE OR COPIES THEREOF CANNOT BE MADE WITHOUT WRITTEN CONSENT.

CUSTOMER NAME: \_\_\_\_\_  
**APPROVED** BY: \_\_\_\_\_ DATE: \_\_\_\_\_

**CONTAINMENT SOLUTIONS**

DRAWN BY: \_\_\_\_\_ DATE DRAWN: 01-01-14  
 DWG NUMBER: 5100263 SCALE: 1:32  
 REV: \_\_\_\_\_ REV BY: \_\_\_\_\_ DATE: \_\_\_\_\_ SHEET: 1 OF 1