

**NOTE:**  
**OVERALL SHIPPING DIMENSION: 7'-10" L X 3'-5" W X 3'-11" H**

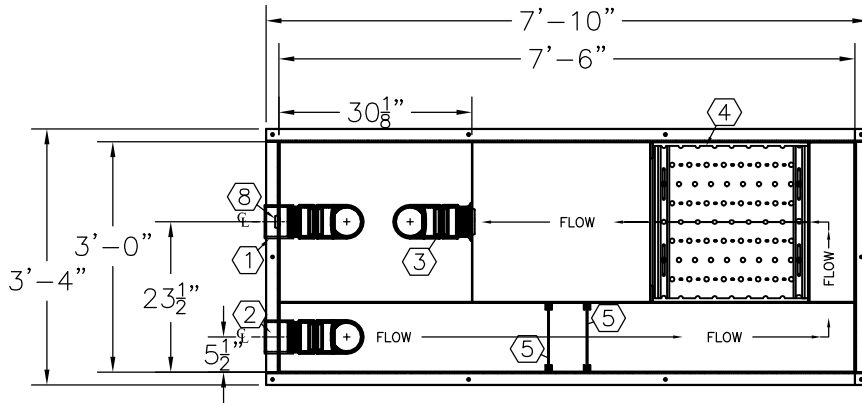

ITEM	SIZE	SUGGESTED FUNCTION
1	4"	EFFLUENT
2	4"	INFLUENT
3	4"	TRANSFER PIPE
4		COALESCER
5		DEBRIS PLATES
6	2" X 12"	OIL EQUALIZING ORIFICE
7		COVER, DWG."CVB003"
8	1"	FLOAT SENSOR NPT FTG.
9	2"	OIL DRAW W/PIPE

**TANK SPECIFICATIONS**  
**MATERIAL: PRIMARY TANK - 10 GA.**

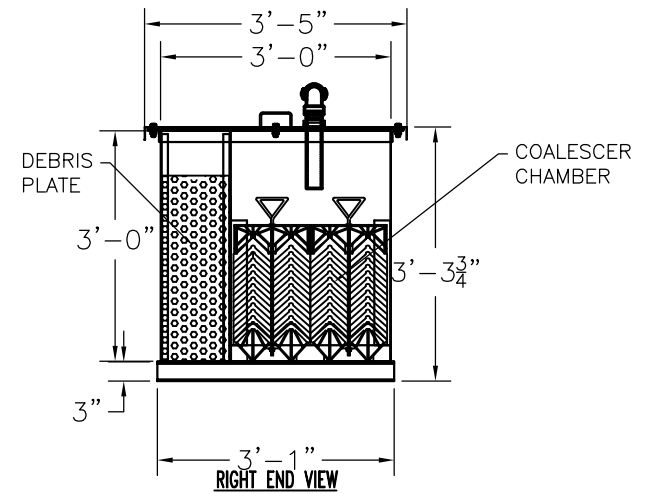
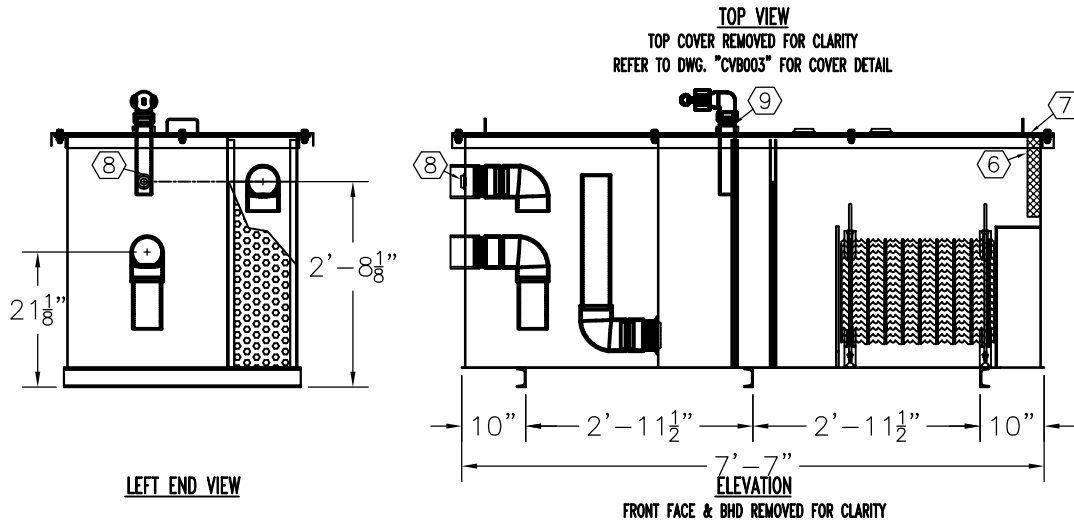

PRODUCT CODE	GALLONS	DESCRIPTION	OVERALL SIZE	SHIP WT.
WSAA1500SS000	500	SINGLE WALL OIL WATER SEPARATOR (50 GPM)	7'-7" L X 3'-1" W X 3'-4" H	1,225 LBS.

THIS DRAWING AND DESIGN SHOWN HEREIN IS THE PROPERTY OF CONTAINMENT SOLUTIONS. USE OR COPIES THEREOF CANNOT BE MADE WITHOUT WRITTEN CONSENT.

CUSTOMER NAME: \_\_\_\_\_  
**APPROVED** BY: \_\_\_\_\_ DATE: \_\_\_\_\_

**CONTAINMENT SOLUTIONS®**

DRAWN BY: \_\_\_\_\_ DATE DRAWN: 01-01-14  
 DWG NUMBER: 5100262 SCALE: 1:30  
 REV: \_\_\_\_\_ REV BY: \_\_\_\_\_ DATE: \_\_\_\_\_ SHEET: 1 OF 1