

NOTE:
 OVERALL SHIPPING DIMENSION: 6'-4" L X 2'-5" W X 3'-11" H

ITEM	SIZE	SUGGESTED FUNCTION
1	3"	EFFLUENT
2	2"	INFLUENT
3	3"	TRANSFER PIPE
4		COALESCER
5		DEBRIS PLATES
6	2" X 12"	OIL EQUALIZING ORIFICE
7		COVER, DWG."CVB002"
8	1"	FLOAT SENSOR NPT FTG.
9	2"	OIL DRAW W/PIPE

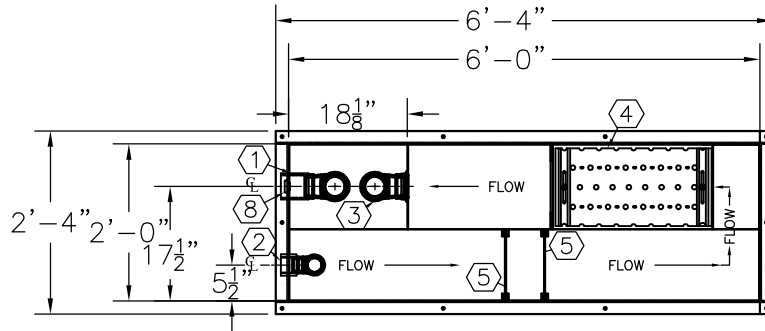

TANK SPECIFICATIONS
 MATERIAL: PRIMARY TANK - 10 GA.

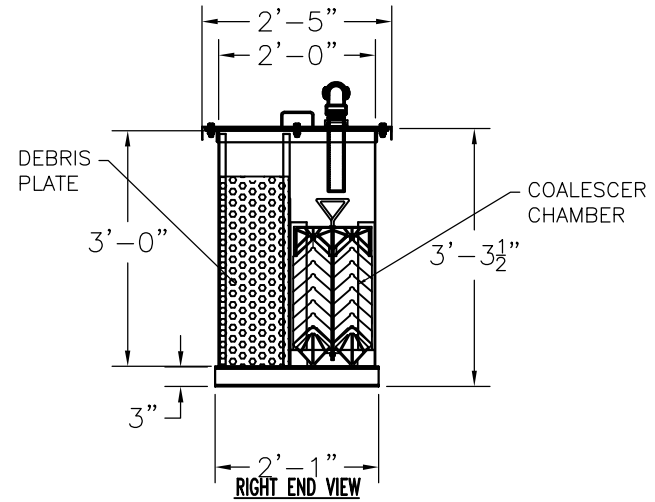
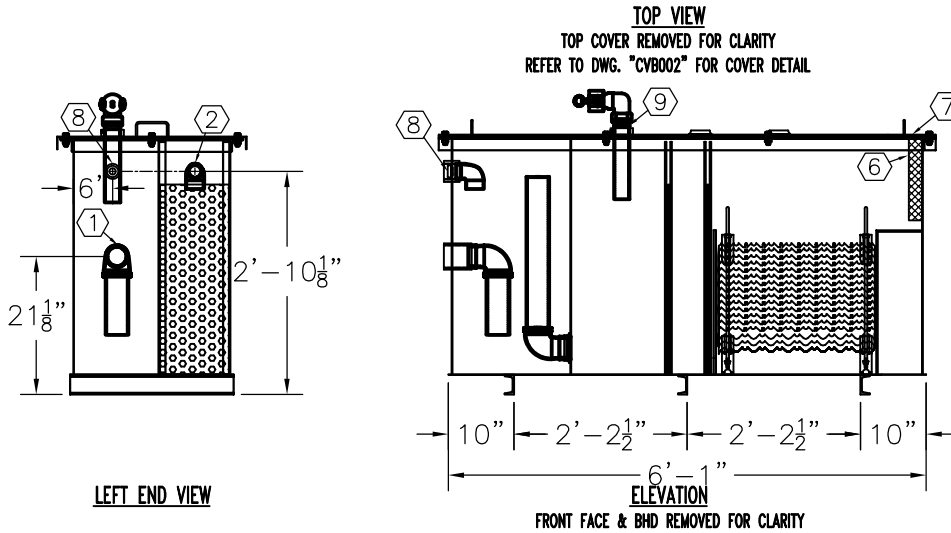

PRODUCT CODE	GALLONS	DESCRIPTION	OVERALL SIZE	SHIP WT.
WSAA1250SS000	250	SINGLE WALL OIL WATER SEPARATOR (25 GPM)	6'-1" L X 2'-1" W X 3'-5" H	775 LBS.

THIS DRAWING AND DESIGN SHOWN HEREIN IS THE PROPERTY OF CONTAINMENT SOLUTIONS. USE OR COPIES THEREOF CANNOT BE MADE WITHOUT WRITTEN CONSENT.

CUSTOMER NAME: _____
APPROVED BY: _____ DATE: _____

CONTAINMENT SOLUTIONS

DRAWN BY: _____ DATE DRAWN: 01-01-14
 DWG NUMBER: 5100261 SCALE: 1:30
 REV: _____ REV BY: _____ DATE: _____ SHEET: 1 OF 1