

NOTE:

OVERALL SHIPPING DIMENSION: 17'-0" L X 4'-5" W X 4'-11" H

ITEM	SIZE	SUGGESTED FUNCTION
1	8"	EFFLUENT
2	8"	INFLUENT
3	8"	TRANSFER PIPE
4		COALESCER
5		DEBRIS PLATES
6	2" X 18"	OIL EQUALIZING ORIFICE
7		COVER, DWG."CVB006"
8	1"	FLOAT SENSOR NPT FTG.
9	2"	OIL DRAW W/PIPE

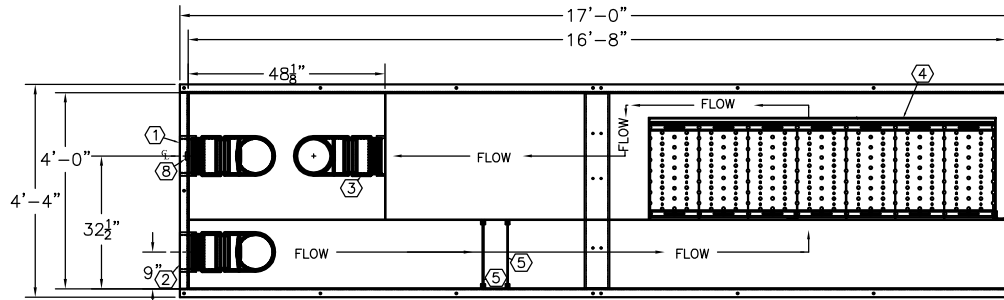

TOP VIEW
TOP COVER REMOVED FOR CLARITY
REFER TO DWG. "CVB006" FOR COVER DETAIL

TANK SPECIFICATIONS

MATERIAL: PRIMARY TANK - 3/16" THK.

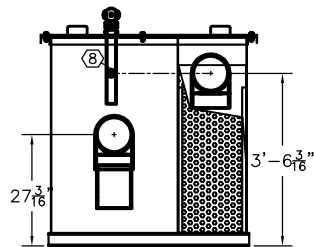

LEFT END VIEW

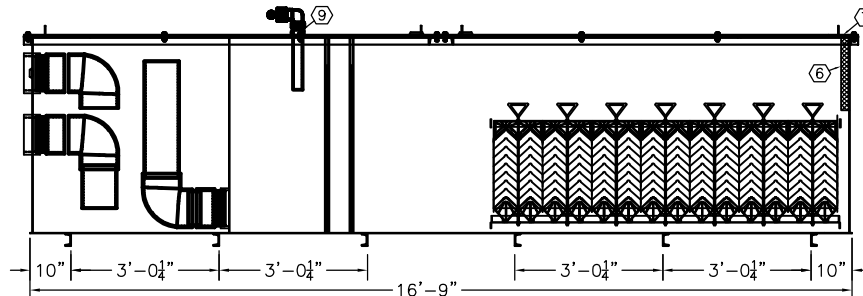

ELEVATION
FRONT FACE & BHD REMOVED FOR CLARITY

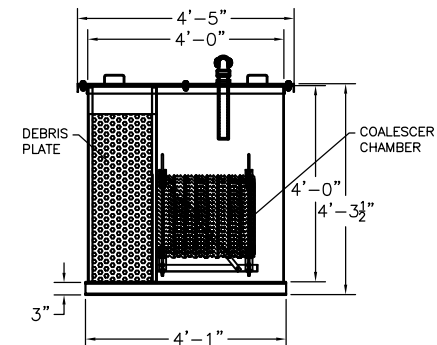

RIGHT END VIEW

PRODUCT CODE	GALLONS	DESCRIPTION	OVERALL SIZE	SHIP WT.
WSAA102MSS000	2,000	SINGLE WALL OIL WATER SEPARATOR (200 GPM)	16'-9" L X 4'-1" W X 4'-4" H	4,200 LBS.

THIS DRAWING AND DESIGN SHOWN HEREIN IS THE PROPERTY OF CONTAINMENT SOLUTIONS. USE OR COPIES THEREOF CANNOT BE MADE WITHOUT WRITTEN CONSENT.

CUSTOMER NAME: _____

APPROVED BY: _____ DATE: _____

CONTAINMENT SOLUTIONS

DRAWN BY:	DATE DRAWN: 01-01-14
DWG NUMBER: 5100265	SCALE: 1:48
REV:	REV BY: DATE: SHEET: 1 OF 1