

NOTE:
OVERALL SHIPPING DIMENSION: 11'-2" L X 5'-5" W X 5'-2" H

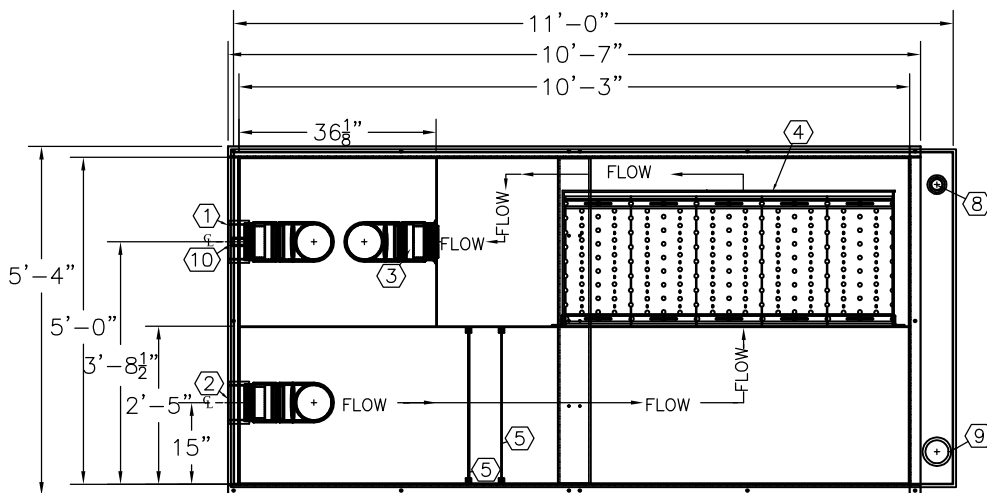

ITEM	SIZE	SUGGESTED FUNCTION
1	6"	EFFLUENT
2	6"	INFLUENT
3	6"	TRANSFER PIPE
4		COALESCER
5		DEBRIS PLATES
6	2" X 18"	OIL EQUALIZING ORIFICE
7		COVER, DWG."CVB029"
8	2"	SECONDARY WORKING VENT
9	4"	SECONDARY CONTAINMENT EMERGENCY VENT
10	1"	FLOAT SENSOR NPT FTG.
11	2"	OIL DRAW W/PIPE

TANK SPECIFICATIONS

MATERIAL: PRIMARY TANK - 3/16" THK.

TOP VIEW
 TOP COVER REMOVED FOR CLARITY
 REFER TO DWG. "CVB023" FOR COVER DETAIL

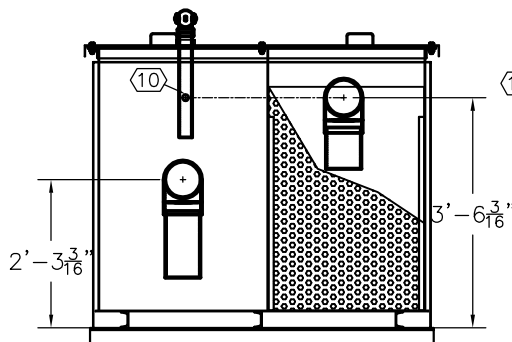

LEFT END VIEW

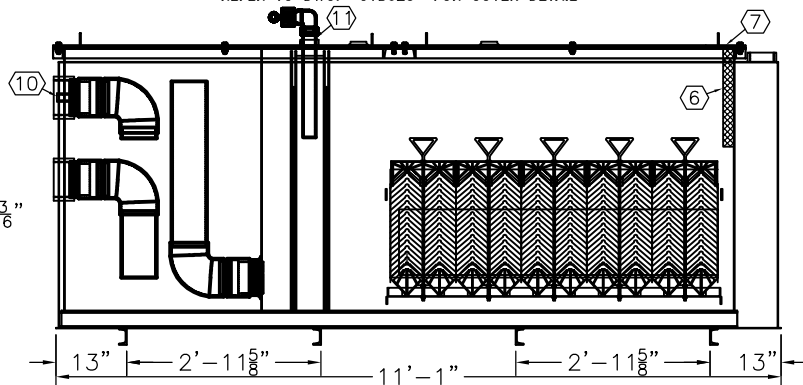

ELEVATION
 FRONT FACE & BHD REMOVED FOR CLARITY

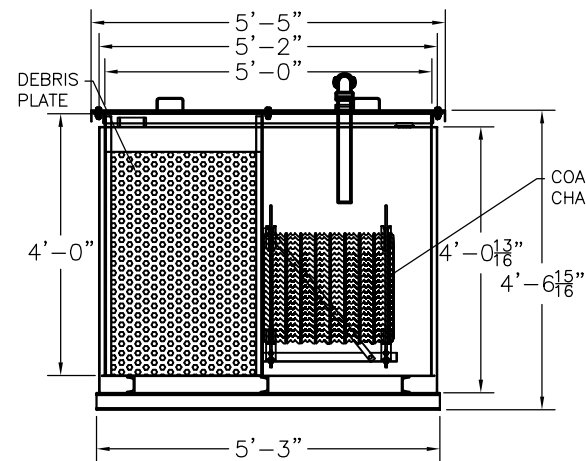

RIGHT END VIEW

PRODUCT CODE	GALLONS	DESCRIPTION	OVERALL SIZE	SHIP WT.
WSAA115CDS000	1,500	DOUBLE WALL OIL WATER SEPARATOR (150 GPM)	11'-1" L X 5'-3" W X 4'-7" H	5,450 LBS.

THIS DRAWING AND DESIGN SHOWN HEREIN IS THE PROPERTY OF CONTAINMENT SOLUTIONS. USE OR COPIES THEREOF CANNOT BE MADE WITHOUT WRITTEN CONSENT.

CUSTOMER NAME: _____
APPROVED BY: _____ DATE: _____

CONTAINMENT SOLUTIONS

DRAWN BY: D. ROVANG DATE DRAWN: 01-01-14
 DWG NUMBER: 5104316 SCALE: 1:36
 REV: _____ REV BY: _____ DATE: _____ SHEET: 1 OF 1